

**ISOMETRIC VIEW
(FRONT)**

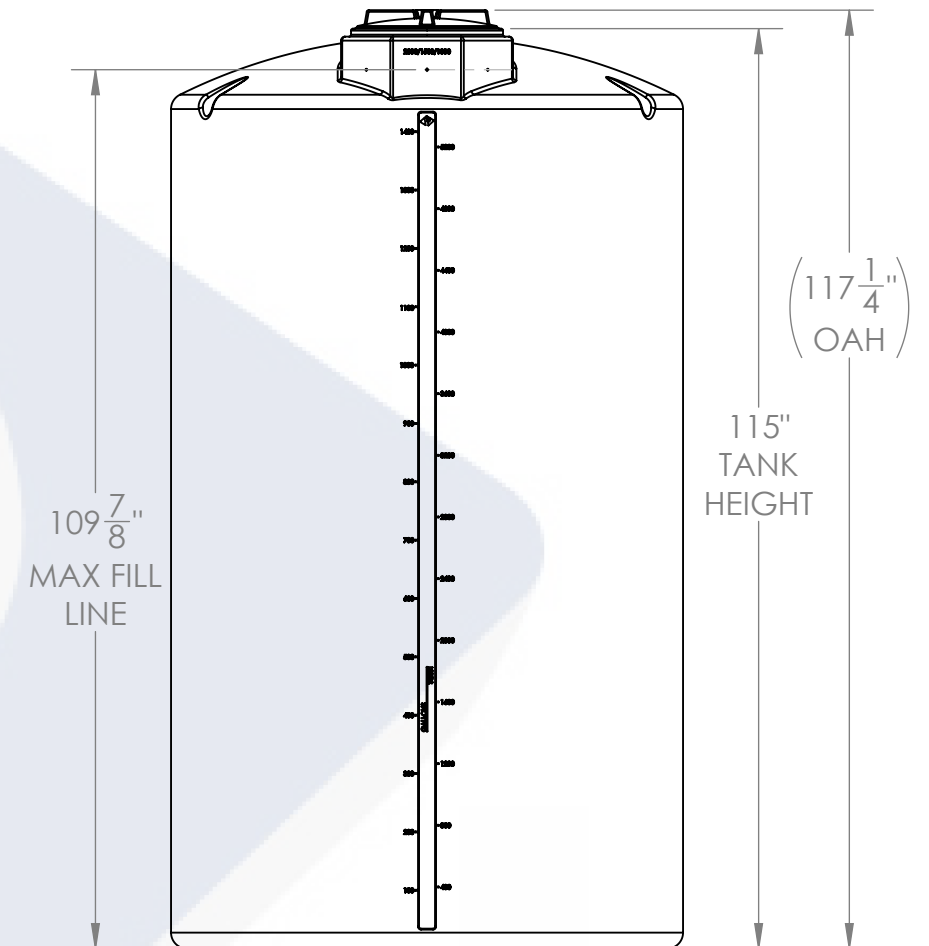
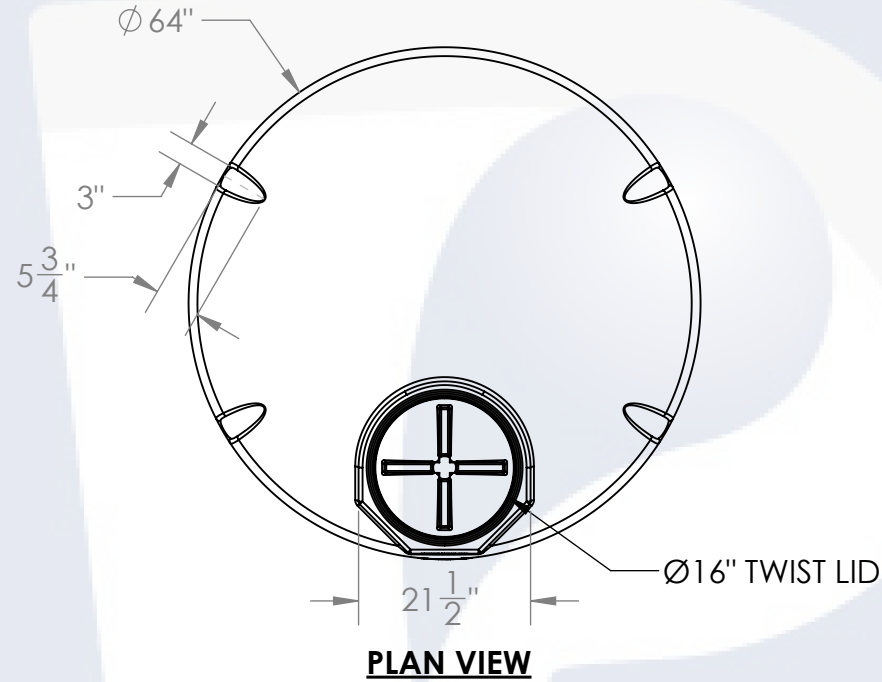

FRONT VIEW

NOTES:

1. CAPACITY: 1500 GAL. NOMINAL
2. TANK MATERIAL OPTIONS:
LPE 1.5, LPE 1.9, XLPE, FDA WATER, PPL, PVDF
3. SERVICE PRESSURE: ATMOSPHERIC
4. NSF/ANSI STANDARD 61 CERTIFIED
5. AVAILABLE W/FRP WRAP
CONTACT CUSTOMER SERVICE FOR MORE INFO

PROPRIETARY AND CONFIDENTIAL
 THE INFORMATION CONTAINED IN THIS DRAWING IS THE SOLE PROPERTY OF PEABODY ENGINEERING. ANY REPRODUCTION IN PART OR AS A WHOLE WITHOUT THE WRITTEN PERMISSION OF PEABODY ENGINEERING IS PROHIBITED.

UNLESS OTHERWISE SPECIFIED:		NAME	DATE	HPTC-34040-PB		
DIMENSIONS ARE IN INCHES TOLERANCES: $\pm 1/4''$ ANGULAR: $\pm .5^\circ$ ONE PLACE DECIMAL: $\pm .25$ TWO PLACE DECIMAL: $\pm .125$ THREE PLACE DECIMAL: $\pm .063$		DRAWN	SMF 04/10/23			
TANK MATERIAL:		CHECKED		PROJECT: PROCHEM® TANKS		
INNER TANK S/N:		ENG APPR.		CUSTOMER: PEABODY STANDARD		
OUTER TANK S/N:		MFG APPR.		SITE/LOCATION: -		
CUSTOMER PO#		Q.A.		SALES ORDER: -		
DO NOT SCALE DRAWING				SIZE	DESC.	REV.
				B	$\phi 64''$ X 118" 1500G PROCHEM TANK	A
		SCALE: 1:24		SHEET 1 OF 1		