

D  
C  
B  
A

D  
C  
B  
A

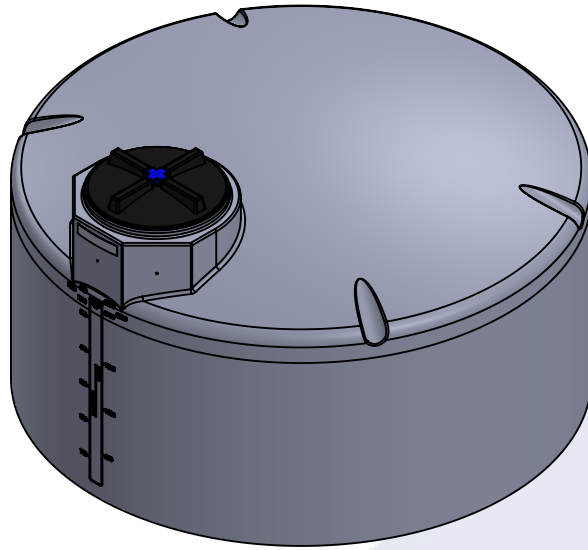

**ISOMETRIC VIEW**

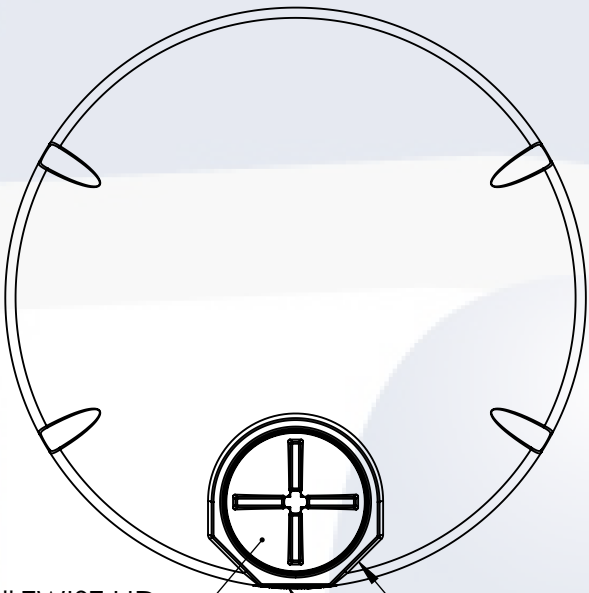

**PLAN VIEW**

16" TWIST LID  
ACCEPTS 2" BULKHEADS, TYP.  
ACCEPTS 3" BULKHEADS

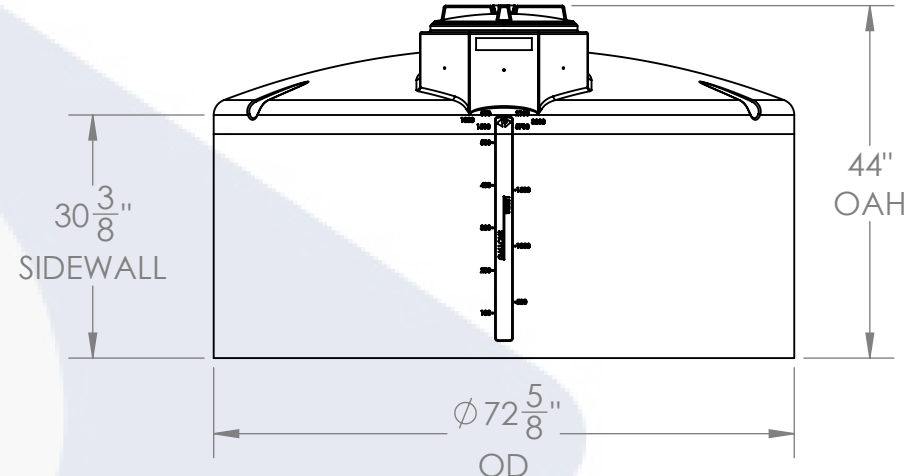

**FRONT VIEW**

550 GAL PROCHEM® PROCESS TANK 72.625 X 44	PART NUMBER	
	PROCESS CHEMICAL (NATURAL)	POTABLE WATER (BLACK)
LPE (1.0)	01-34035	01-33432
LPE (1.5)	01-33429	N/A
LPE (1.9)	01-33430	N/A
XLPE (1.9)	01-33431	N/A

*ALTERNATIVE MATERIALS, COLOR, AND ACCESSORIES ARE AVAILABLE. CALL FOR ADDITIONAL INFO*

Heritage Products

Sales@heritagepro.com

- NOTES:**
- CAPACITY: 550 GAL. NOMINAL
  - TANK MATERIAL OPTIONS: LPE 1.5, LPE 1.9, XLPE, FDA WATER, PPL, PVDF
  - SERVICE PRESSURE: ATMOSPHERIC
  - NSF/ANSI STANDARD 61 CERTIFIED
  - AVAILABLE W/FRP WRAP  
CONTACT CUSTOMER SERVICE FOR MORE INFO

**PROPRIETARY AND CONFIDENTIAL**  
THE INFORMATION CONTAINED IN THIS DRAWING IS THE SOLE PROPERTY OF PEABODY ENGINEERING. ANY REPRODUCTION IN PART OR AS A WHOLE WITHOUT THE WRITTEN PERMISSION OF IS PROHIBITED.

UNLESS OTHERWISE SPECIFIED:  
DIMENSIONS ARE IN INCHES  
TOLERANCES: ±1/4"  
ANGULAR: ±.5°  
ONE PLACE DECIMAL: ±.25  
TWO PLACE DECIMAL: ±.125  
THREE PLACE DECIMAL: ±.063

TANK MATERIAL:  
INNER TANK S/N:  
OUTER TANK S/N:  
CUSTOMER PO#

DO NOT SCALE DRAWING

	NAME	DATE
DRAWN	SMF	02/08/22
CHECKED		
ENG APPR.		
MFG APPR.		
Q.A.		



<b>HPTC-34035-PB</b>		
PROJECT: <b>PROCHEM® TANKS</b>		
CUSTOMER:		
SITE/LOCATION: -		
SALES ORDER: <b>SEE TABLE</b>		
SIZE	DESC.	REV.
<b>B</b>	<b>550 GAL PROCHEM® PROCESS TANK 72.625 X 44</b>	-
SCALE: 1:24		SHEET 1 OF 1