

**ISOMETRIC VIEW**

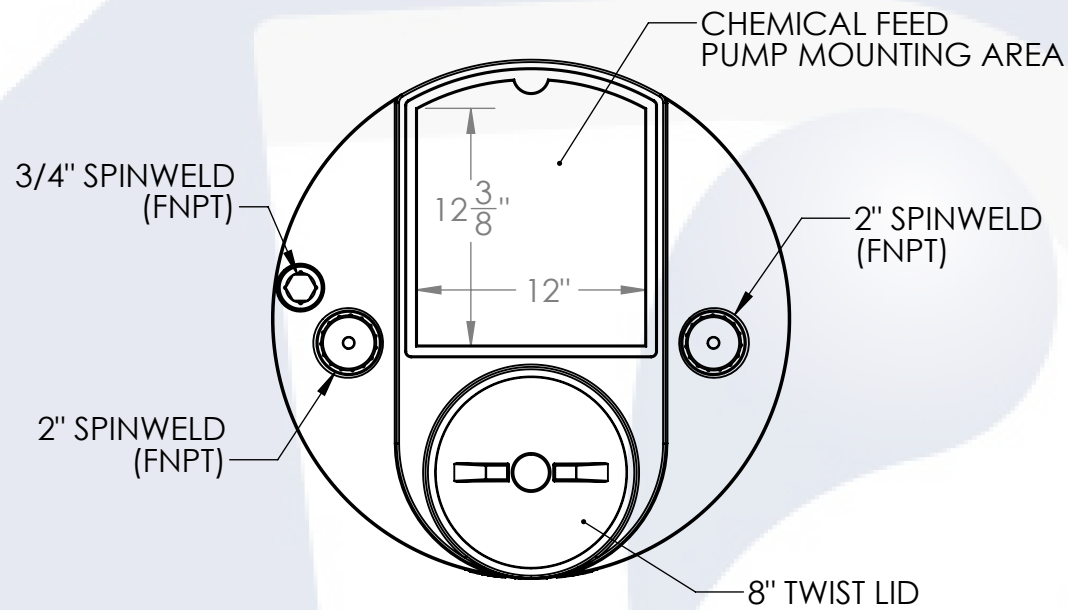

**PLAN VIEW**

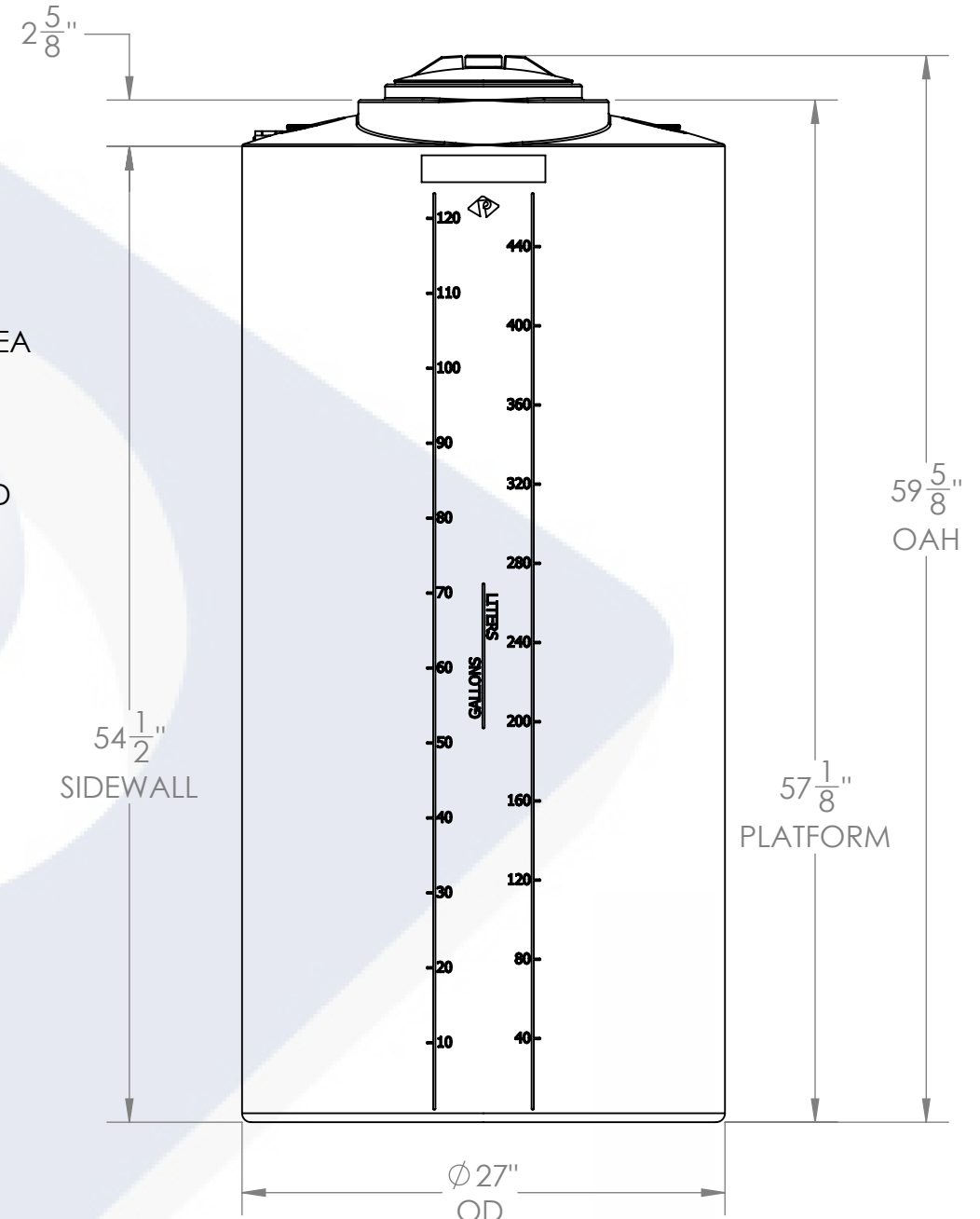

**FRONT VIEW**

| 125 GAL PROCHEM® PROCESS TANK, Ø27" x 59.5" | PART NUMBER                |                       |
|---|----------------------------|-----------------------|
|   | PROCESS CHEMICAL (NATURAL) | POTABLE WATER (BLACK) |
| LPE (1.0)                                   | 01-34029                   | 01-31868              |
| LPE (1.5)                                   | 01-31688                   | N/A                   |
| LPE (1.9)                                   | 01-31687                   | N/A                   |
| XLPE (1.9)                                  | 01-31693                   | N/A                   |

ALTERNATIVE MATERIALS, COLOR, AND ACCESSORIES ARE AVAILABLE. CALL FOR ADDITIONAL INFO

**NOTES:**

- CAPACITY: 125 GAL. NOMINAL
- TANK MATERIAL OPTIONS: LPE 1.5, LPE 1.9, XLPE, FDA WATER, PPL, PVDF
- SERVICE PRESSURE: ATMOSPHERIC
- NSF/ANSI STANDARD 61 CERTIFIED
- AVAILABLE W/FRP WRAP  
CONTACT CUSTOMER SERVICE FOR MORE INFO

**PROPRIETARY AND CONFIDENTIAL**  
THE INFORMATION CONTAINED IN THIS DRAWING IS THE SOLE PROPERTY OF PEABODY ENGINEERING. ANY REPRODUCTION IN PART OR AS A WHOLE WITHOUT THE WRITTEN PERMISSION OF IS PROHIBITED.

UNLESS OTHERWISE SPECIFIED:  
DIMENSIONS ARE IN INCHES  
TOLERANCES: ±1/4"  
ANGULAR: ±.5°  
ONE PLACE DECIMAL: ±.25  
TWO PLACE DECIMAL: ±.125  
THREE PLACE DECIMAL: ±.063

TANK MATERIAL:  
INNER TANK S/N:  
OUTER TANK S/N:  
CUSTOMER PO#

DO NOT SCALE DRAWING

|           | NAME | DATE     |
|-----------|------|----------|
| DRAWN     | AAF  | 11/01/19 |
| CHECKED   |      |          |
| ENG APPR. |      |          |
| MFG APPR. |      |          |
| Q.A.      |      |          |



|                                |  |              |
|--------------------------------|--|--------------|
| <b>HPTC-34029-PB</b>           |  |              |
| PROJECT: <b>PROCHEM® TANKS</b> |  |              |
| CUSTOMER:                      |  |              |
| SITE/LOCATION:                 |  |              |
| SALES ORDER: <b>SEE TABLE</b>  |  |              |
| SIZE                           | DESC.  | REV.         |
| <b>B</b>                       | <b>125 GAL PROCHEM® PROCESS TANK, Ø27" x 59.5"</b> | <b>C</b>     |
| SCALE: 1:10                    |  | SHEET 1 OF 1 |