

ISOMETRIC VIEW

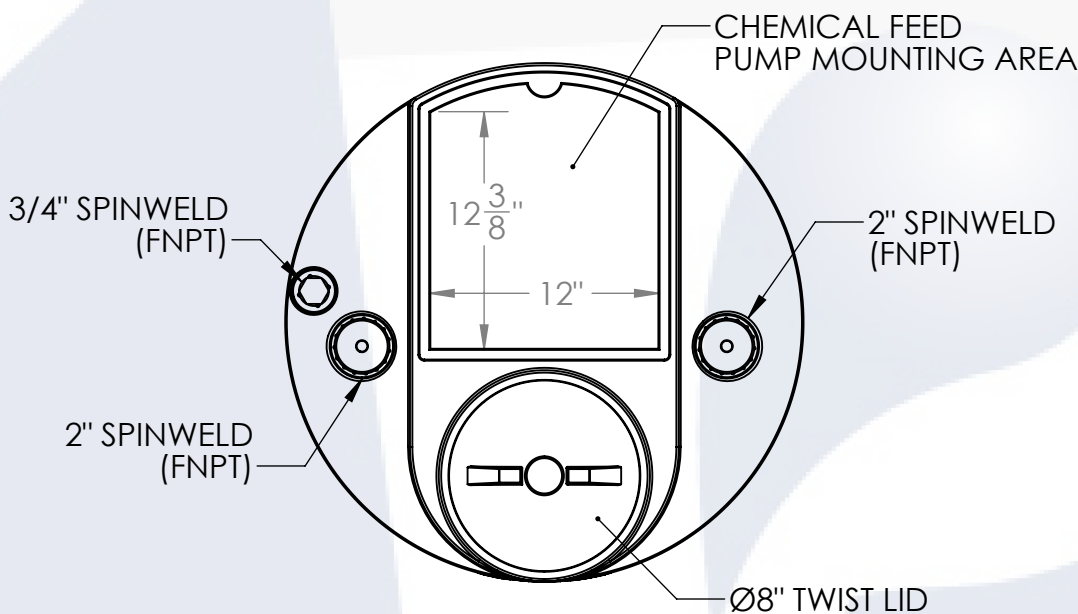

PLAN VIEW

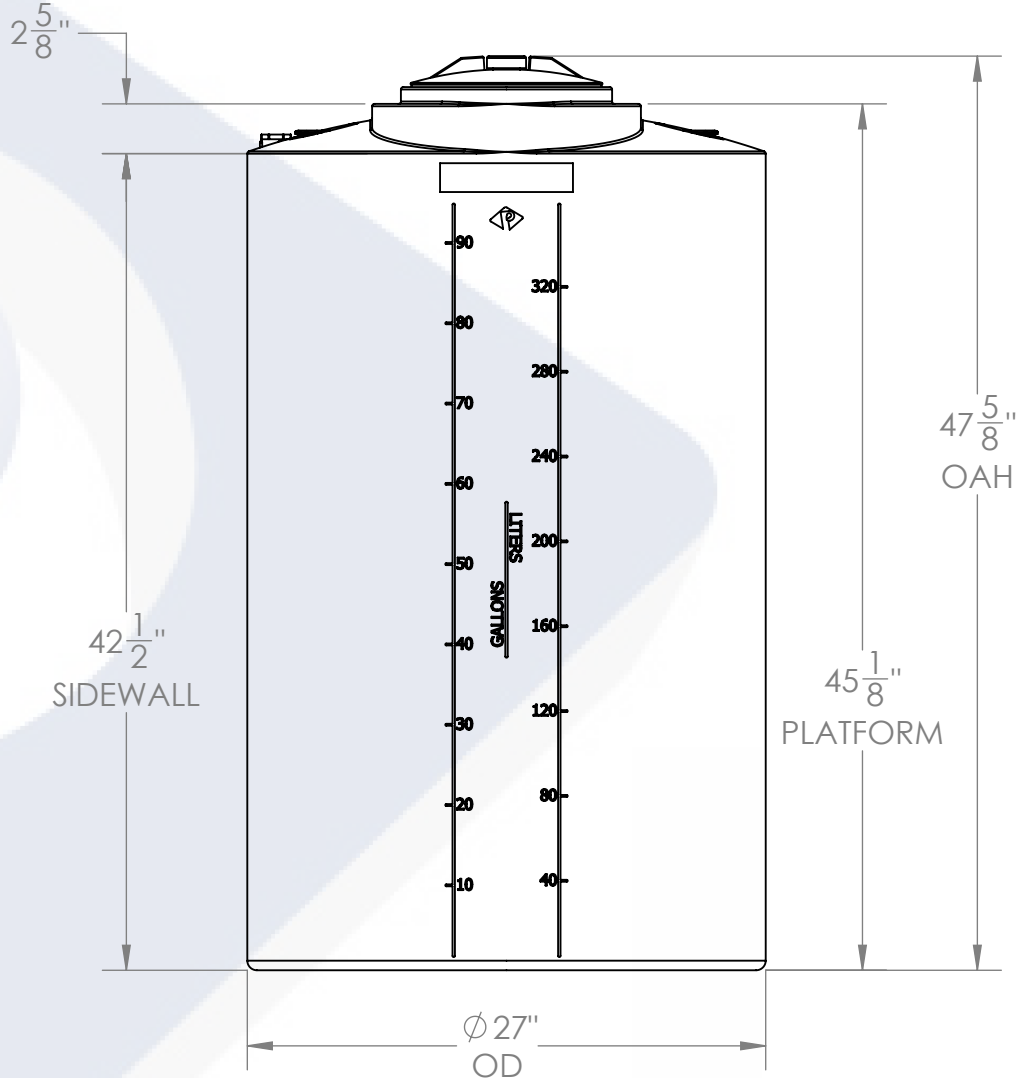

FRONT VIEW

100 GAL PROCHEM® PROCESS TANK, Ø27" x 39.5"	PART NUMBER	
	PROCESS CHEMICAL (NATURAL)	POTABLE WATER (BLACK)
LPE (1.0)	01-34028	01-31867
LPE (1.5)	01-31274	N/A
LPE (1.9)	01-31264	N/A
XLPE (1.9)	01-31324	N/A

ALTERNATIVE MATERIALS, COLOR, AND ACCESSORIES ARE AVAILABLE. CALL FOR ADDITIONAL INFO

- NOTES:
- CAPACITY: 100 GAL. NOMINAL
  - TANK MATERIAL OPTIONS: LPE 1.5, LPE 1.9, XLPE, FDA WATER, PPL, PVDF
  - SERVICE PRESSURE: ATMOSPHERIC
  - NSF/ANSI STANDARD 61 CERTIFIED
  - AVAILABLE W/FRP WRAP
- CONTACT CUSTOMER SERVICE FOR MORE INFO

**PROPRIETARY AND CONFIDENTIAL**

THE INFORMATION CONTAINED IN THIS DRAWING IS THE SOLE PROPERTY OF PEABODY ENGINEERING. ANY REPRODUCTION IN PART OR AS A WHOLE WITHOUT THE WRITTEN PERMISSION OF IS PROHIBITED.

UNLESS OTHERWISE SPECIFIED:  
 DIMENSIONS ARE IN INCHES  
 TOLERANCES: ±1/4"  
 ANGULAR: ±.5°  
 ONE PLACE DECIMAL: ±.25  
 TWO PLACE DECIMAL: ±.125  
 THREE PLACE DECIMAL: ±.063

TANK MATERIAL:  
 INNER TANK S/N:  
 OUTER TANK S/N:  
 CUSTOMER PO#

DO NOT SCALE DRAWING

	NAME	DATE
DRAWN	AAF	11/01/19
CHECKED		
ENG APPR.		
MFG APPR.		
Q.A.		

HPTC-34028-PB		
PROJECT: PROCHEM® TANKS		
CUSTOMER:		
SITE/LOCATION: -		
SALES ORDER: SEE TABLE		
SIZE	DESC.	REV.
B	100 GAL PROCHEM® PROCESS TANK, Ø27" x 39.5"	D
SCALE: 1:10		SHEET 1 OF 1