

ISOMETRIC VIEW

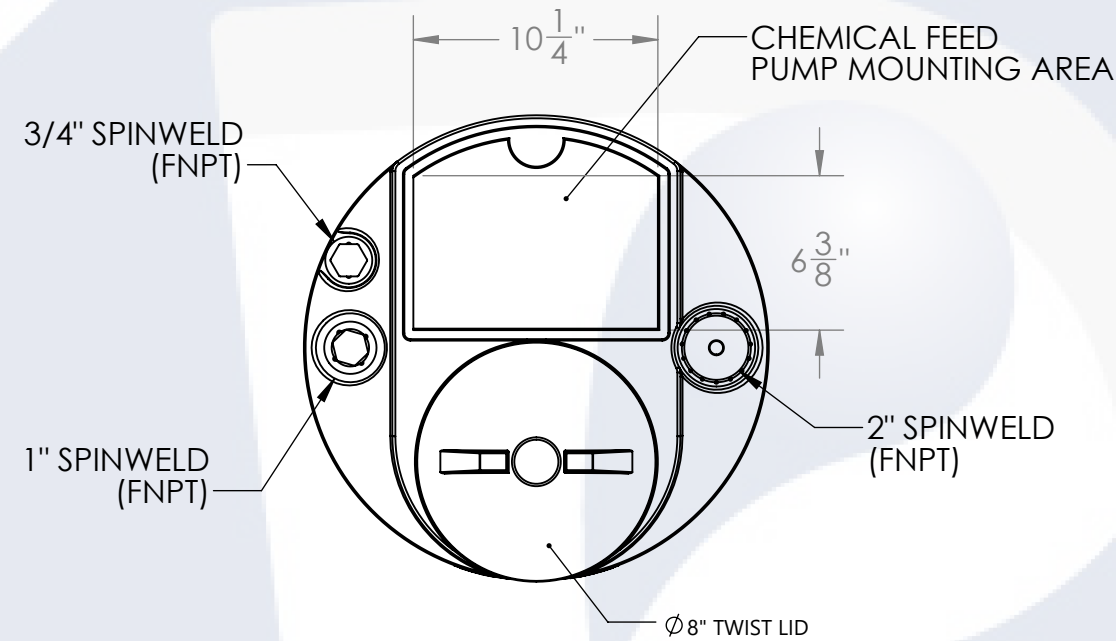

PLAN VIEW

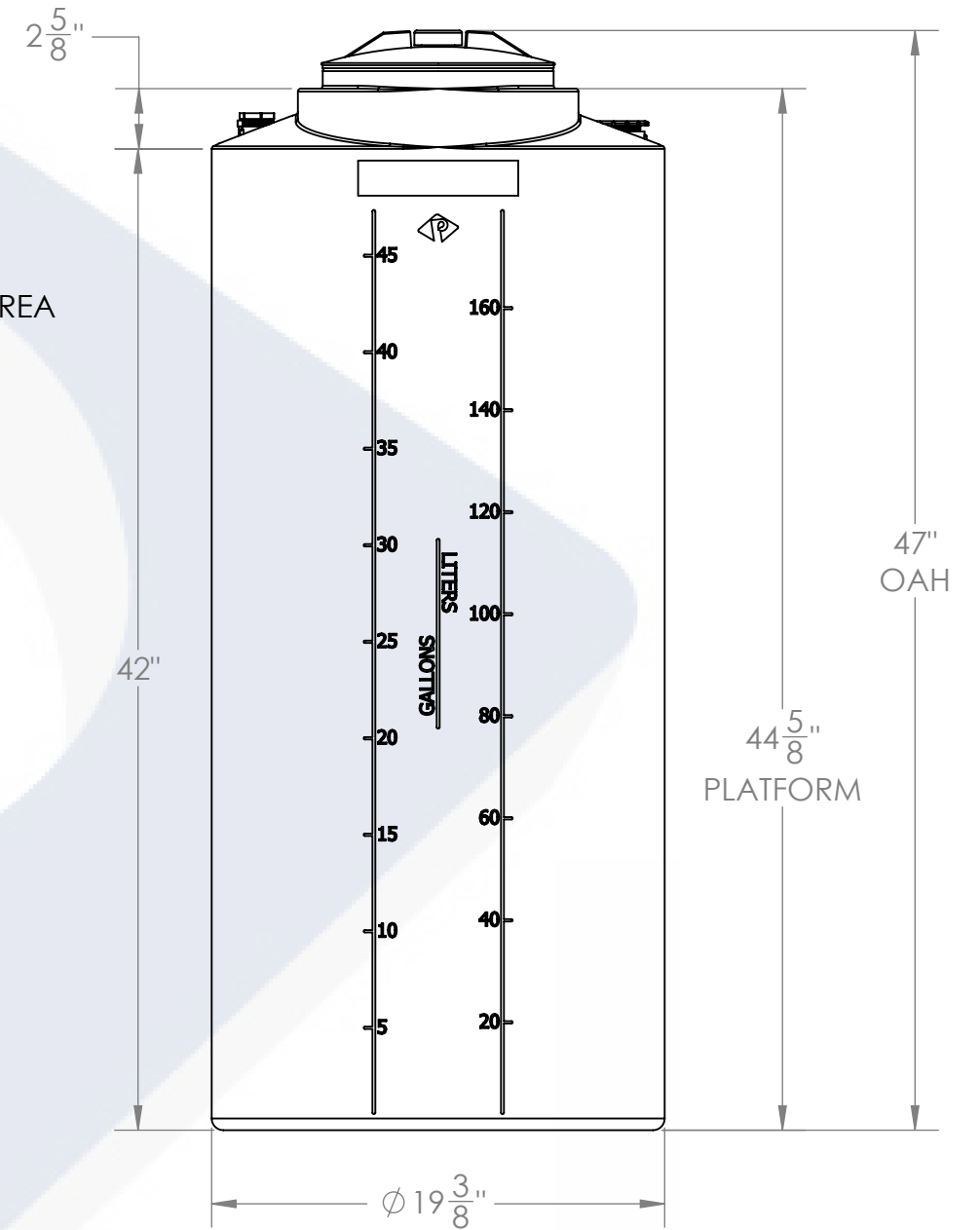

FRONT VIEW

| 50 GAL PROCHEM® PROCESS TANK, Ø19.5" x 47" | PART NUMBER | |
|--|----------------------------|-----------------------|
| | PROCESS CHEMICAL (NATURAL) | POTABLE WATER (BLACK) |
| LPE (1.0) | 01-34025 | 01-31865 |
| LPE (1.5) | 01-31273 | N/A |
| LPE (1.9) | 01-31263 | N/A |
| XLPE (1.9) | 01-31323 | N/A |

ALTERNATIVE MATERIALS, COLOR, AND ACCESSORIES ARE AVAILABLE. CALL FOR ADDITIONAL INFO

NOTES:

- CAPACITY: 50 GAL. NOMINAL
- TANK MATERIAL OPTIONS: LPE 1.5, LPE 1.9, XLPE, FDA WATER, PPL, PVDF
- SERVICE PRESSURE: ATMOSPHERIC
- NSF/ANSI STANDARD 61 CERTIFIED
- AVAILABLE W/FRP WRAP
CONTACT CUSTOMER SERVICE FOR MORE INFO

PROPRIETARY AND CONFIDENTIAL
 THE INFORMATION CONTAINED IN THIS DRAWING IS THE SOLE PROPERTY OF PEABODY ENGINEERING. ANY REPRODUCTION IN PART OR AS A WHOLE WITHOUT THE WRITTEN PERMISSION OF IS PROHIBITED.

UNLESS OTHERWISE SPECIFIED:

DIMENSIONS ARE IN INCHES
 TOLERANCES: ±1/4"
 ANGULAR: ±.5°
 ONE PLACE DECIMAL: ±.25
 TWO PLACE DECIMAL: ±.125
 THREE PLACE DECIMAL: ±.063

TANK MATERIAL:
 INNER TANK S/N:
 OUTER TANK S/N:
 CUSTOMER PO#

DO NOT SCALE DRAWING

| | NAME | DATE |
|-----------|------|----------|
| DRAWN | AAF | 11/01/19 |
| CHECKED | | |
| ENG APPR. | | |
| MFG APPR. | | |
| Q.A. | | |



HPTC-34025-PB

PROJECT: **PROCHEM® TANKS**

CUSTOMER:

SITE/LOCATION: -

SALES ORDER: **SEE TABLE**

| | | |
|----------|---|-----------|
| SIZE | DESC. | REV. |
| B | 50 GAL PROCHEM® PROCESS TANK, Ø19.5" x 47" | E1 |

SCALE: 1:8

SHEET 1 OF 1