

D
C
B
A

D
C
B
A

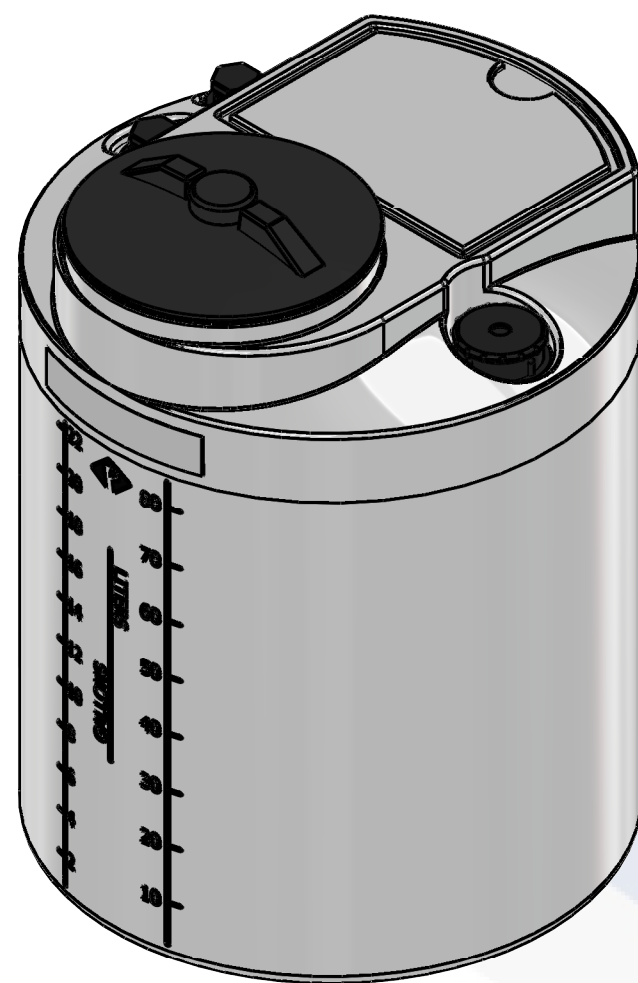

ISOMETRIC VIEW

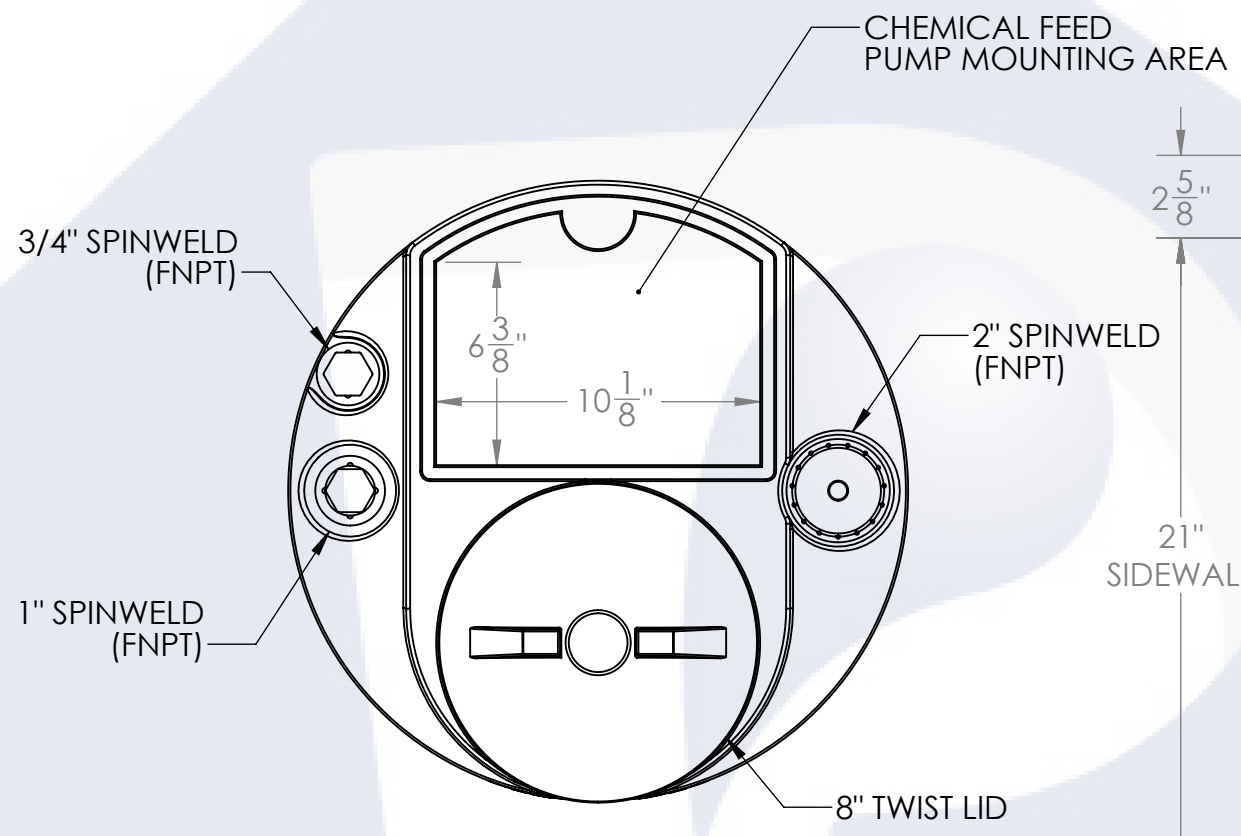

PLAN VIEW

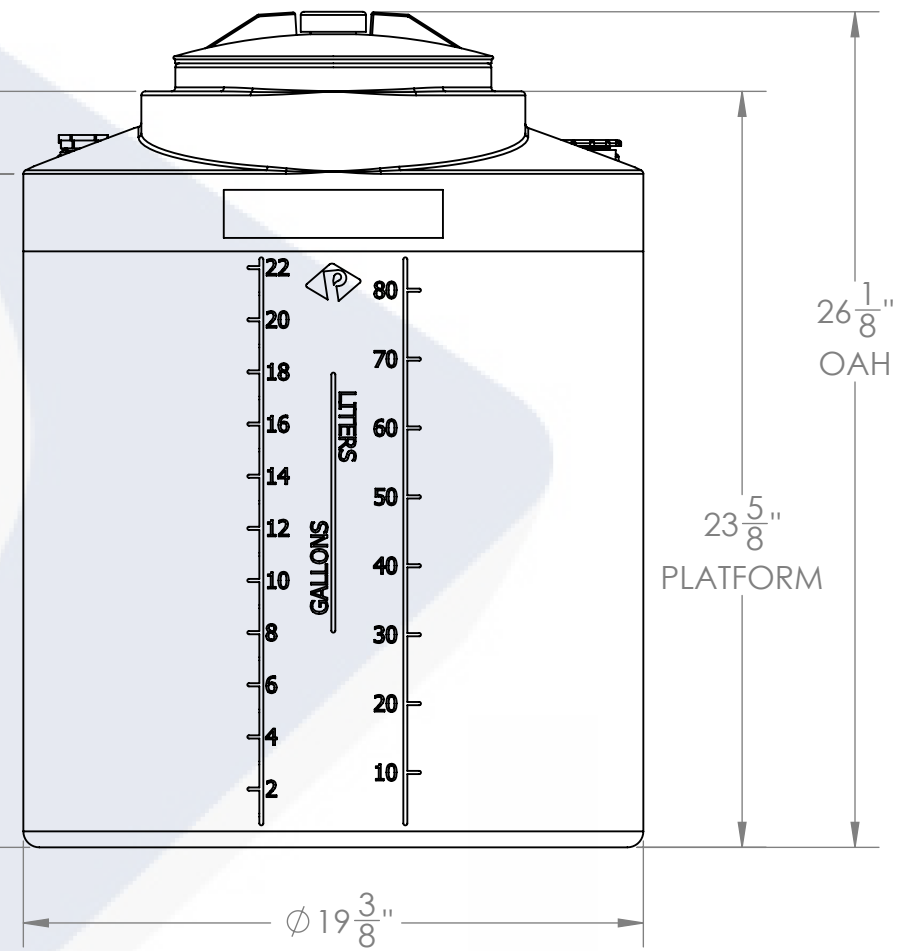

FRONT VIEW

25 GAL PROCHEM® PROCESS TANK, Ø19.5" x 26"	PART NUMBER	
	CHEMICAL (NATURAL)	POTABLE WATER (BLACK)
LPE (1.0)	01-34024	01-31864
LPE (1.5)	01-31272	N/A
LPE (1.9)	01-31262	N/A
XLPE (1.9)	*01-31322	N/A
ALTERNATIVE MATERIALS, COLOR, AND ACCESSORIES ARE AVAILABLE. CALL FOR ADDITIONAL INFO		

- NOTES:
- CAPACITY: 25 GAL. NOMINAL
 - TANK MATERIAL OPTIONS: LPE 1.5, LPE 1.9, XLPE, FDA WATER, PPL, PVDF
 - SERVICE PRESSURE: ATMOSPHERIC
 - NSF/ANSI STANDARD 61 CERTIFIED
4A. PRODUCT MARKED WITH * NOT CERTIFIED
 - AVAILABLE W/FRP WRAP
CONTACT CUSTOMER SERVICE FOR MORE INFO

PROPRIETARY AND CONFIDENTIAL
THE INFORMATION CONTAINED IN THIS DRAWING IS THE SOLE PROPERTY OF PEABODY ENGINEERING. ANY REPRODUCTION IN PART OR AS A WHOLE WITHOUT THE WRITTEN PERMISSION OF IS PROHIBITED.

UNLESS OTHERWISE SPECIFIED:
DIMENSIONS ARE IN INCHES
TOLERANCES: ±1/4"
ANGULAR: ±.5°
ONE PLACE DECIMAL: ±.25
TWO PLACE DECIMAL: ±.125
THREE PLACE DECIMAL: ±.063

TANK MATERIAL:
INNER TANK S/N:
OUTER TANK S/N:
CUSTOMER PO#

DO NOT SCALE DRAWING

	NAME	DATE
DRAWN	AAF	10/31/19
CHECKED		
ENG APPR.		
MFG APPR.		
Q.A.		



Heritage Products

Sales@heritagepro.com

HPTC-34024-PB

PROJECT: PROCHEM® TANKS		
CUSTOMER:		
SITE/LOCATION: -		
SALES ORDER: SEE TABLE		
SIZE	DESC. 25 GAL PROCHEM® PROCESS TANK, Ø19.5" x 26"	REV. G
B		
SCALE: 1:6	SHEET 1 OF 1	