

D  
C  
B  
A

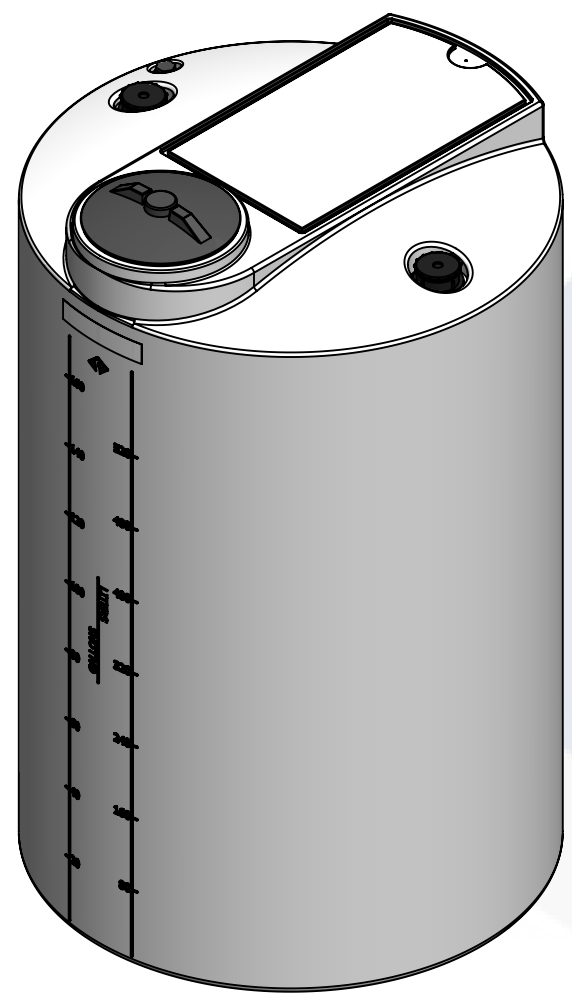

**ISOMETRIC VIEW**

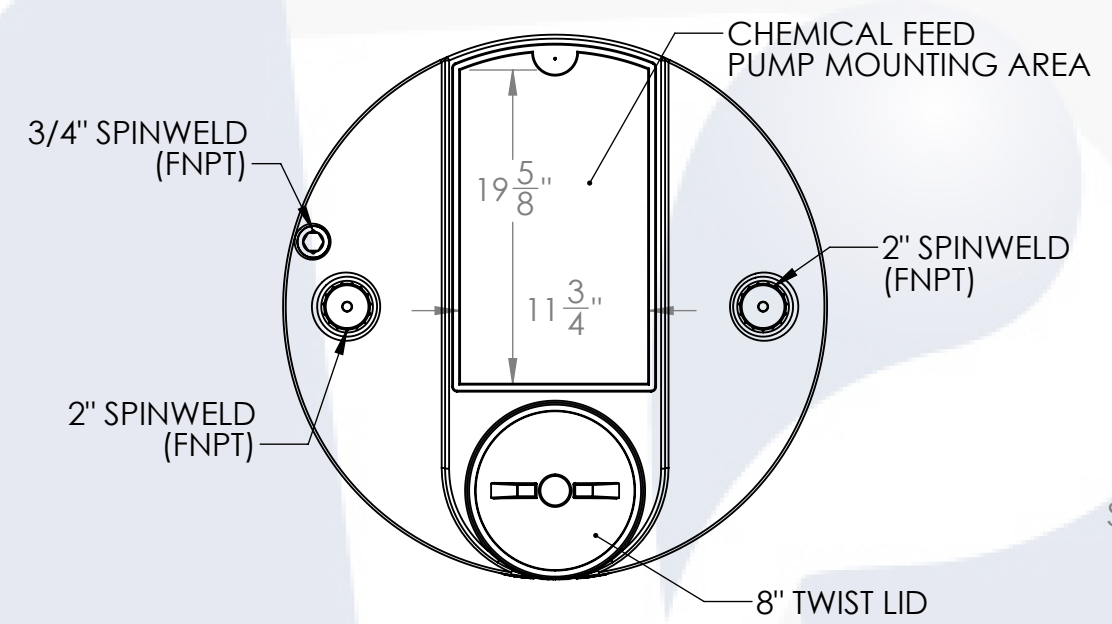

**PLAN VIEW**

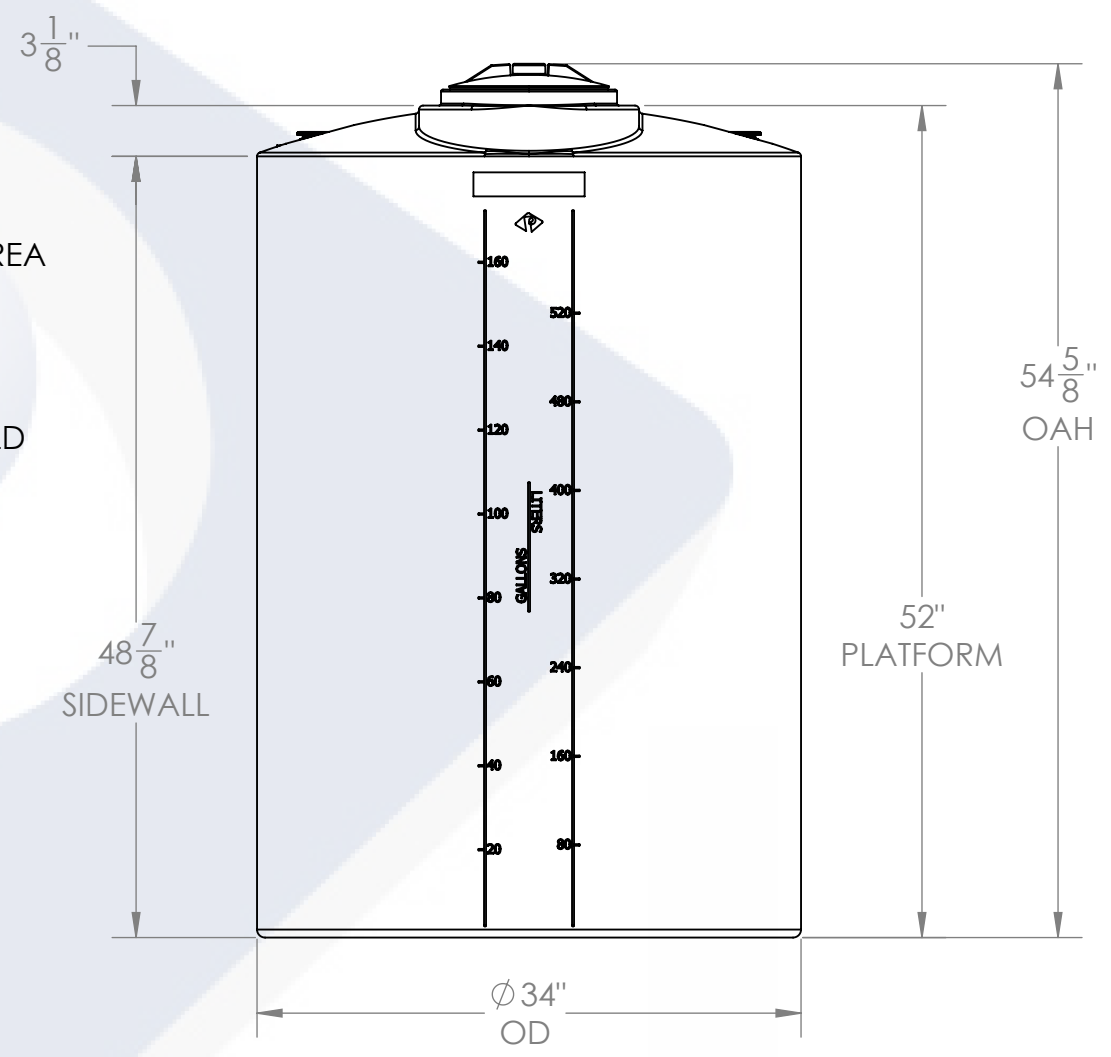

**FRONT VIEW**

175 GAL PROCHEM® PROCESS TANK, Ø34" x 54.5"	PART NUMBER	
	PROCESS CHEMICAL (NATURAL)	POTABLE WATER (BLACK)
LPE (1.0)	01-34030	01-31870
LPE (1.5)	01-31860	N/A
LPE (1.9)	01-31660	N/A
XLPE (1.9)	01-31663	N/A

*ALTERNATIVE MATERIALS, COLOR, AND ACCESSORIES ARE AVAILABLE. CALL FOR ADDITIONAL INFO*

- NOTES:**
- CAPACITY: 175 GAL. NOMINAL
  - TANK MATERIAL OPTIONS: LPE 1.5, LPE 1.9, XLPE, FDA WATER, PPL, PVDF
  - SERVICE PRESSURE: ATMOSPHERIC
  - NSF/ANSI STANDARD 61 CERTIFIED
  - AVAILABLE W/FRP WRAP  
CONTACT CUSTOMER SERVICE FOR MORE INFO

**PROPRIETARY AND CONFIDENTIAL**  
THE INFORMATION CONTAINED IN THIS DRAWING IS THE SOLE PROPERTY OF PEABODY ENGINEERING. ANY REPRODUCTION IN PART OR AS A WHOLE WITHOUT THE WRITTEN PERMISSION OF ENGINEERING IS PROHIBITED.

UNLESS OTHERWISE SPECIFIED:  
DIMENSIONS ARE IN INCHES  
TOLERANCES: ±1/4"  
ANGULAR: ±.5°  
ONE PLACE DECIMAL: ±.25  
TWO PLACE DECIMAL: ±.125  
THREE PLACE DECIMAL: ±.063

TANK MATERIAL:  
INNER TANK S/N:  
OUTER TANK S/N:  
CUSTOMER PO#

DO NOT SCALE DRAWING

	NAME	DATE
DRAWN	AAF	11/01/19
CHECKED		
ENG APPR.		
MFG APPR.		
Q.A.		



<b>HPTC-31860-PB</b>		
PROJECT: <b>PROCHEM® TANKS</b>		
CUSTOMER:		
SITE/LOCATION: -		
SALES ORDER: <b>SEE TABLE</b>		
SIZE	DESC.	REV.
<b>B</b>	<b>175 GAL PROCHEM® PROCESS TANK, Ø34" x 54.5"</b>	<b>C</b>
SCALE: 1:12		SHEET 1 OF 1