

© DEN HARTOG INDUSTRIES, INC.

Copyright. All information furnished within this document, electronic file or design correspondence is the property of Den Hartog Industries, Inc. and shall not be used, disclosed to others or copied without the expressed written consent of Den Hartog Industries, Inc.

IMPORTANT!
NEVER FILL ABOVE THE ADVERTISED CAPACITY OF TANK
FAILURE TO HEED MAY EXCEED THE RATED CAPACITY
OF THE OUTER CONTAINMENT TANK.

DW6000-120

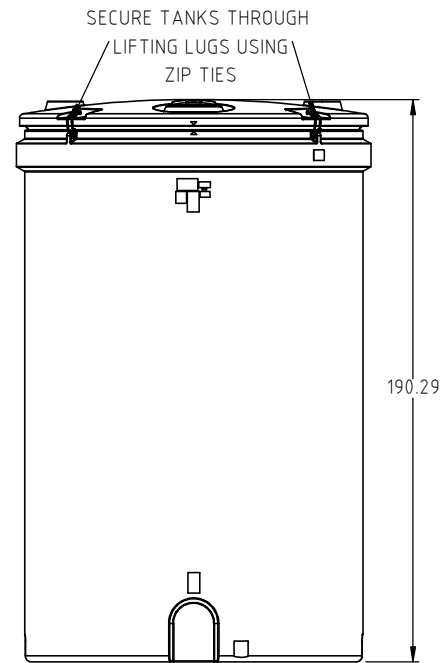
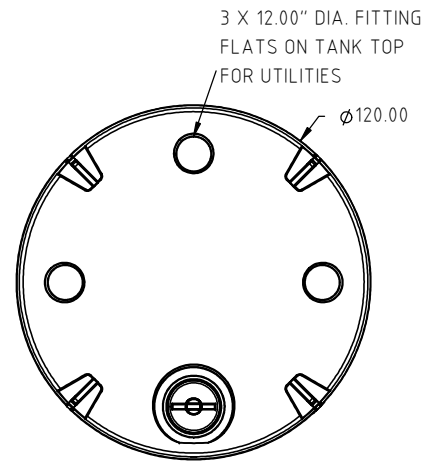
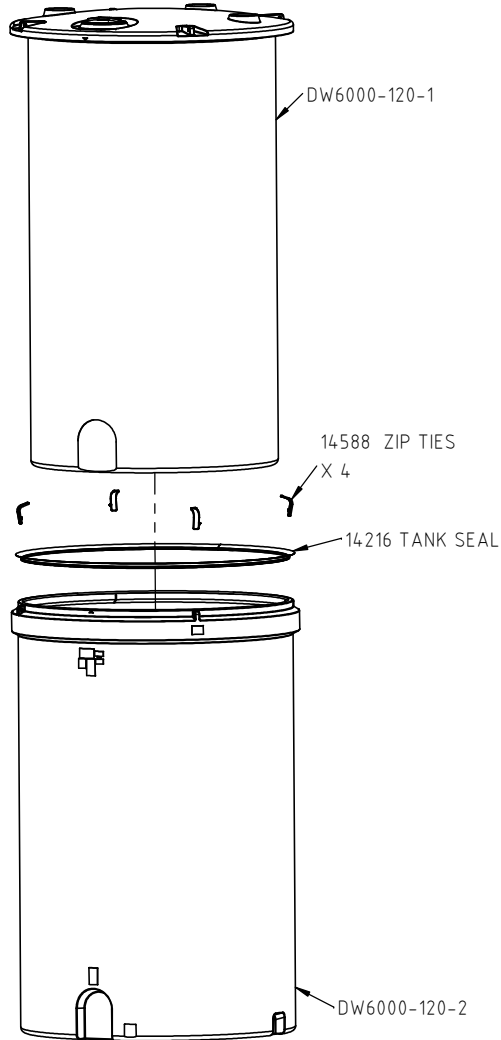

				DRAWN / DATE ADH 1/26/15	MATERIAL SEE NOTE 1
				APPRO. / DATE REH 3/3/17	
REV	DESCRIPTION	BY / DATE	CCN		
ALL DIMENSIONS ARE IN DECIMAL INCHES TOLERANCES UNLESS OTHERWISE SPECIFIED		THIRD ANGLE PROJECTION ANSI 14.5M		SHOT WEIGHT:	NOTES: 1.) REFERENCE COMPONENT PRINTS FOR DETAILS 2.) PATENT 9,162,816
POLYETHYLENE ±1% @ 68°F		METAL DECIMAL ± .125" FRACTION ± 1/4" ANGLE ± 1°		SHIPPING WEIGHT: STANDARD 2951.00 LBS.	
		FINISH:			



Heritage Products (866) 839-1866
Sales@heritagepro.com

4010 HOSPERS DRIVE S. BOX 425, HOSPERS, IOWA 51238-0425

DESCRIPTION 6000 GALLON DUAL LINE™ TANK ASSEMBLY	
SCALE N.S.	PART NO. DW6000-120

Copyright. All information furnished within this document, electronic file or design correspondence is the property of Den Hartog Industries, Inc. and shall not be used, disclosed to others or copied without the expressed written consent of Den Hartog Industries, Inc.

10528
16" LID
10284 STAINLESS STEEL SCREW
X 8

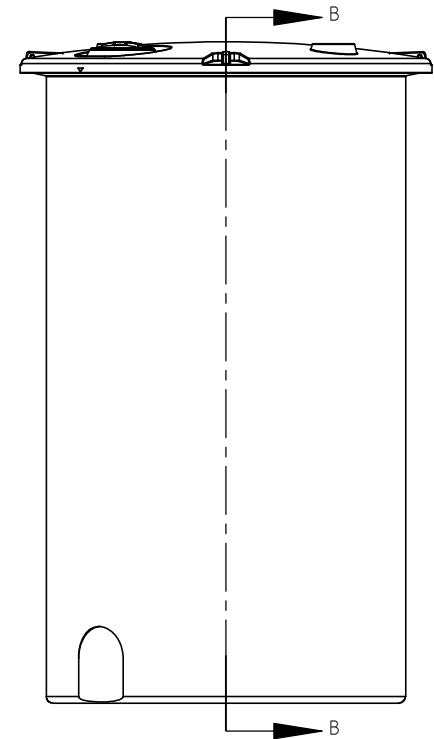
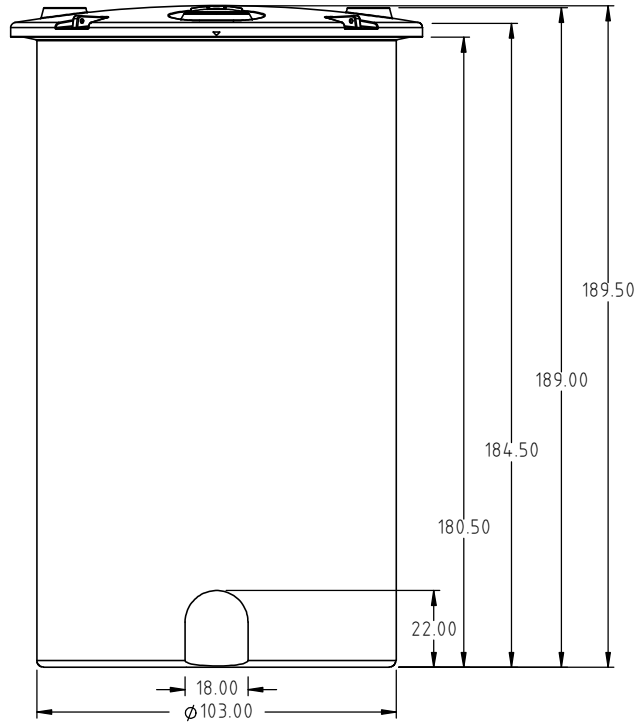
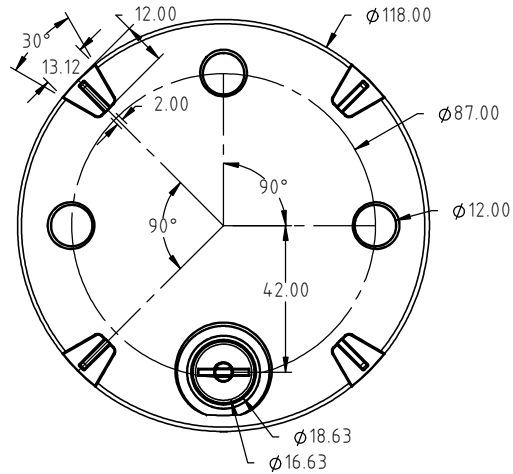
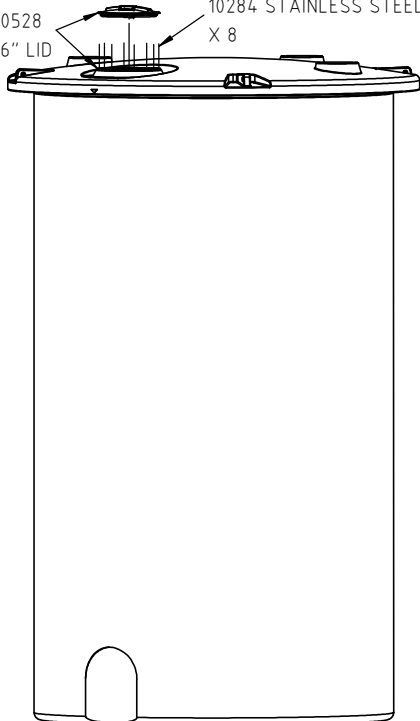

SEE SHEET
2 OF 2 FOR
DETAILS

				DRAWN / DATE ADH 3/11/14	MATERIAL 10538
				APPRD. / DATE REH 3/2/17	
REV	DESCRIPTION	BY / DATE	CCN		
ALL DIMENSIONS ARE IN DECIMAL INCHES TOLERANCES UNLESS OTHERWISE SPECIFIED		THIRD ANGLE PROJECTION ANSI 14.5M		SHOT WEIGHT: 1550.00 LBS	NOTES: 1.) 0.96 WALL @ FLAT 2.) PATENT 9,162,816
POLYETHYLENE ±1% @ 68°F		METAL DECIMAL ± .125" FRACTION ± 1/4" ANGLE ± 1°		SHIPPING WEIGHT: 1552.00 LBS	
		FINISH:			



4010 HOSPERS DRIVE S. BOX 425, HOSPERS, IOWA 51238-0425

DESCRIPTION 6000 GALLON DOUBLE WALL TANK-INNER TANK-1 OF 2	
SCALE N.S.	PART NO. DW6000-120-1

© DEN HARTOG INDUSTRIES, INC.

Copyright. All information furnished within this document, electronic file or design correspondence is the property of Den Hartog Industries, Inc. and shall not be used, disclosed to others or copied without the expressed written consent of Den Hartog Industries, Inc.

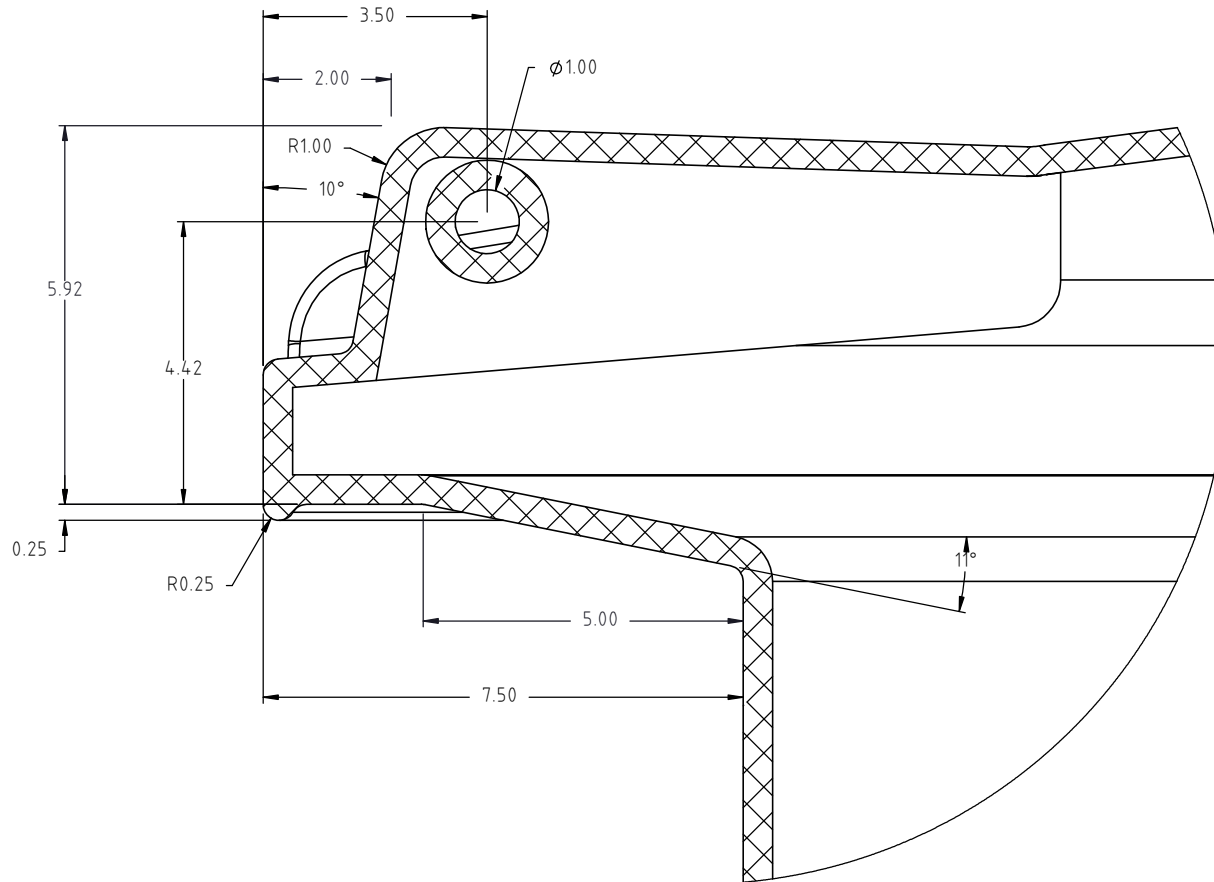

DETAIL E
SCALE 1:3

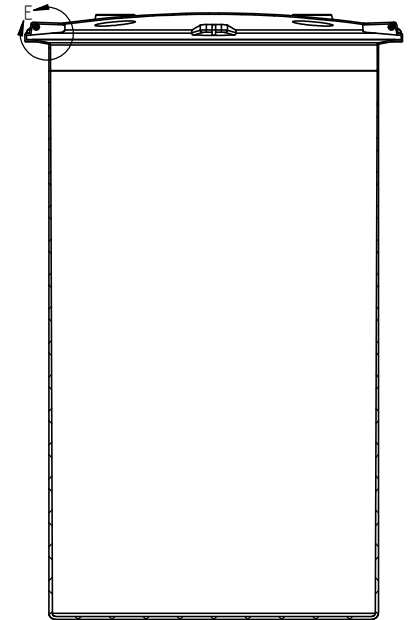

SECTION D-D
SCALE 1:60

				DRAWN / DATE ADH 3/11/14		MATERIAL	
				APPROD. / DATE REH 3/2/17			
REV	DESCRIPTION	BY / DATE	CCN	SHOT WEIGHT:		NOTES:	
ALL DIMENSIONS ARE IN DECIMAL INCHES TOLERANCES UNLESS OTHERWISE SPECIFIED				SHIPPING WEIGHT:			
POLYETHYLENE				FINISH:			
±1% @ 68°F		THIRD ANGLE PROJECTION ANSI 14.5M		DESCRIPTION 6000 GALLON DOUBLE WALL TANK-INNER TANK- 2 OF 2		SCALE N.S.	
METAL DECIMAL ± .125" FRACTION ± 1/4" ANGLE ± 1°				4010 HOSPERS DRIVE S. BOX 425, HOSPERS, IOWA 51238-0425		PART NO.	

© DEN HARTOG INDUSTRIES, INC.

Copyright. All information furnished within this document, electronic file or design correspondence is the property of Den Hartog Industries, Inc. and shall not be used, disclosed to others or copied without the expressed written consent of Den Hartog Industries, Inc.

DW6000-120-2

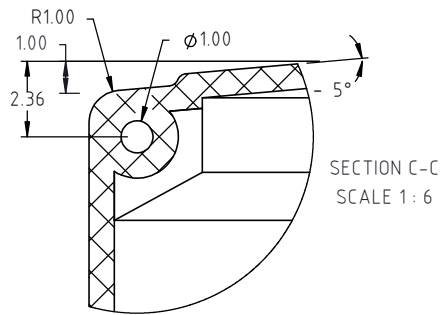
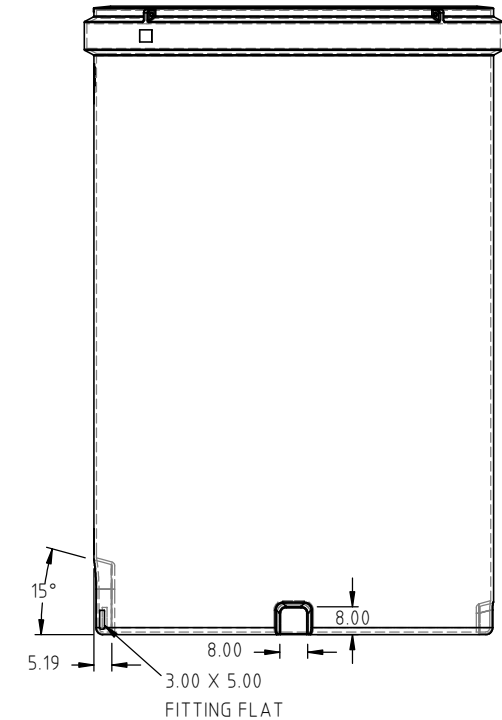
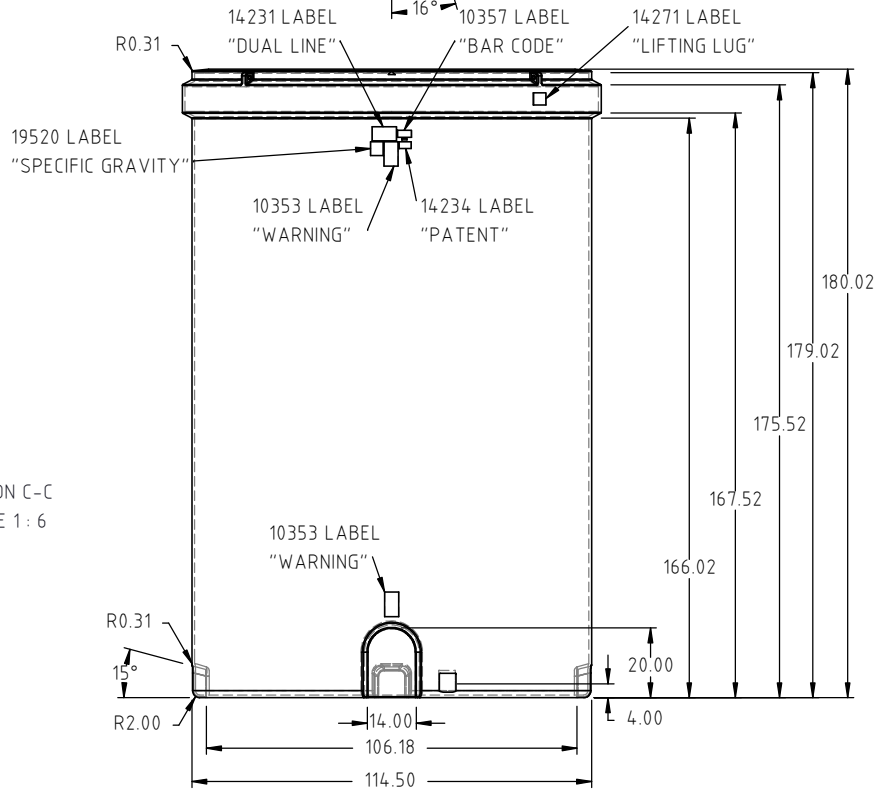
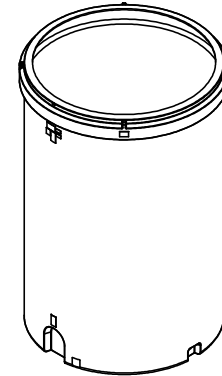
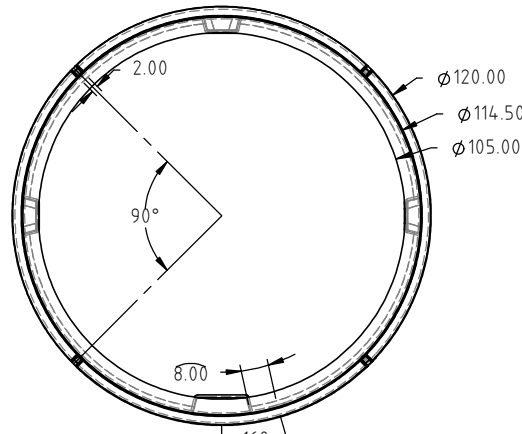
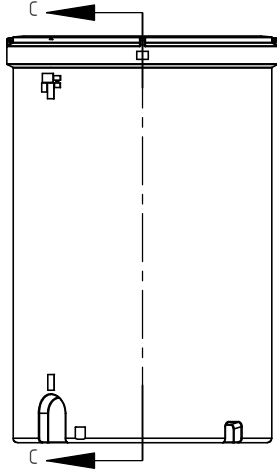

REV	DESCRIPTION	BY / DATE	CCN	DRAWN / DATE ADH 3/19/14	MATERIAL 10538
				APPRO. / DATE REH 3/2/17	
ALL DIMENSIONS ARE IN DECIMAL INCHES TOLERANCES UNLESS OTHERWISE SPECIFIED		THIRD ANGLE PROJECTION ANSI 14.5M		SHOT WEIGHT: 1550.00 LBS	NOTES: 1.) 0.80 WALL @ FLAT
POLYETHYLENE		METAL DECIMAL ± .125" FRACTION ± 1/4" ANGLE ± 1°		SHIPPING WEIGHT: 1399.00 LBS	2.) PATENT 9,162,816
±1% @ 68°F				FINISH:	



DESCRIPTION 6000 GALLON DOUBLE WALL TANK- OUTER TANK	
SCALE N.S.	PART NO. DW6000-120-2