

© DEN HARTOG INDUSTRIES, INC.

Copyright. All information furnished within this document, electronic file or design correspondence is the property of Den Hartog industries, Inc. and shall not be used, disclosed to others or copied without the expressed written consent of Den Hartog Industries, Inc.

STANDARD TANK ASSEMBLY

TANK ASSEMBLY WITH OPTIONAL 2" FITTING

DW0300-57

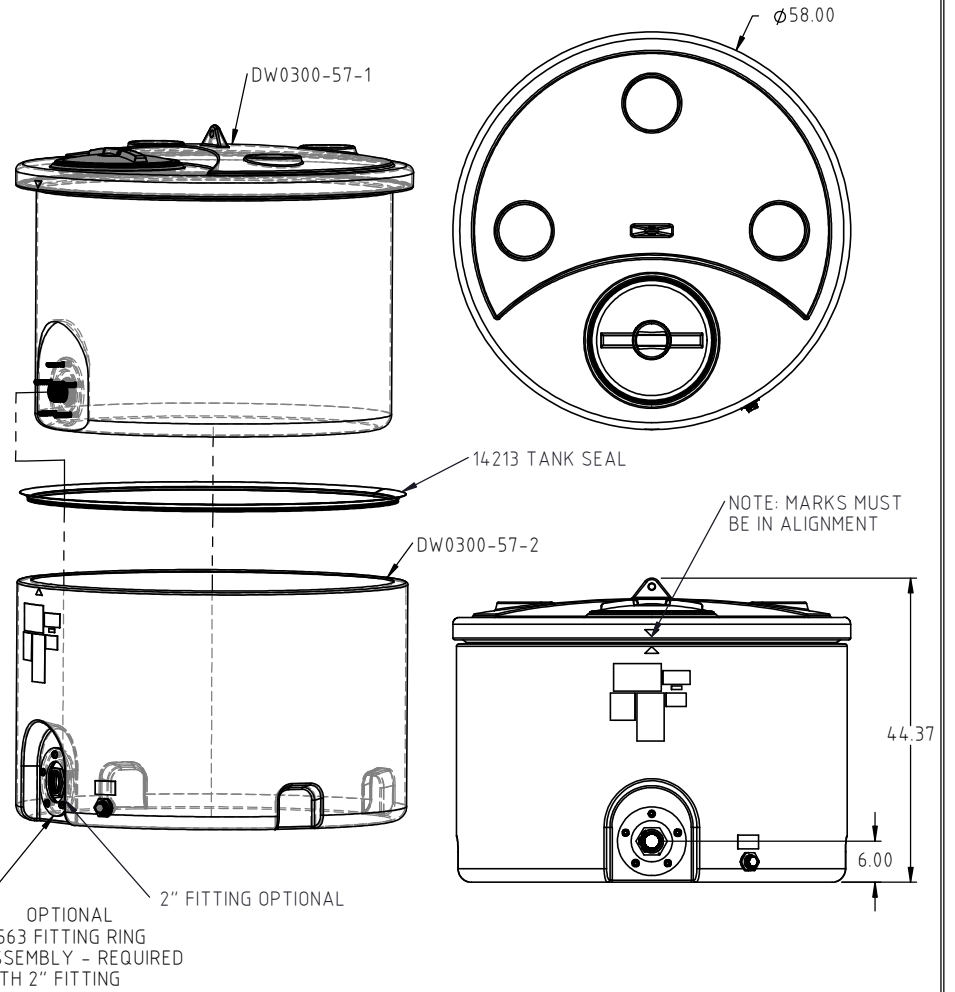
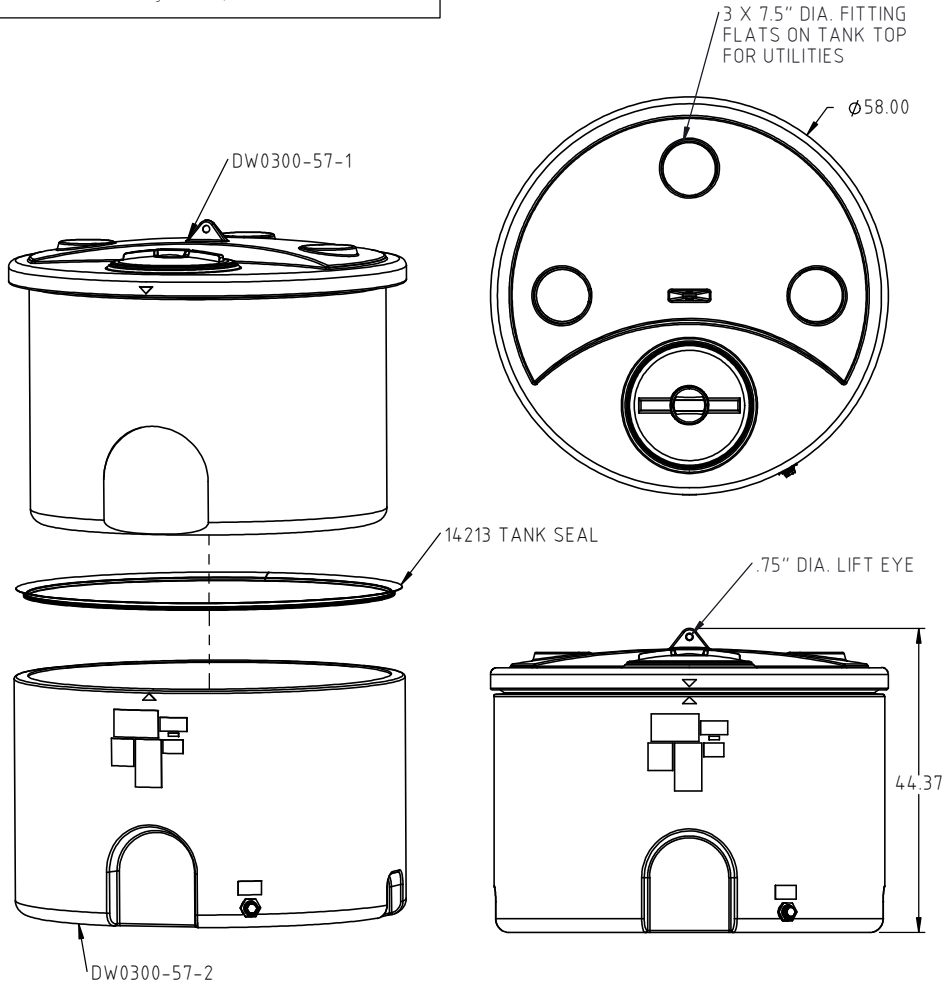

				DRAWN / DATE ADH 8/7/14	MATERIAL SEE NOTE 1
				APPRO. / DATE REH 8/12/14	
REV	DESCRIPTION	BY / DATE	CCN		
ALL DIMENSIONS ARE IN DECIMAL INCHES TOLERANCES UNLESS OTHERWISE SPECIFIED		THIRD ANGLE PROJECTION ANSI 14.5M		SHOT WEIGHT:	NOTES: 1.) REFERENCE COMPONENT PRINTS FOR DETAILS 2.) PATENT PENDING
POLYETHYLENE ±1% @ 68°F		METAL DECIMAL ± .125" FRACTION ± 1/4" ANGLE ± 1°		SHIPPING WEIGHT: STANDARD = 190 LBS. FINISH:	



Heritage Products (866) 839-1866
Sales@heritagepro.com

4010 HOSPERS DRIVE S. BOX 425, HOSPERS, IOWA 51238-0425

DESCRIPTION 300 GALLON DUAL LINE™ TANK ASSEMBLY	
SCALE N.S.	PART NO. HPTC-DW300-DH

Copyright. All information furnished within this document, electronic file or design correspondence is the property of Den Hartog Industries, Inc. and shall not be used, disclosed to others or copied without the expressed written consent of Den Hartog Industries, Inc.

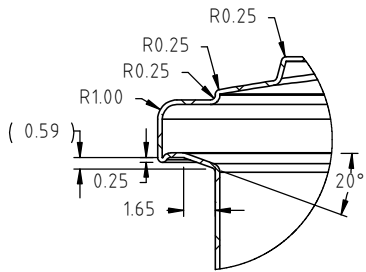
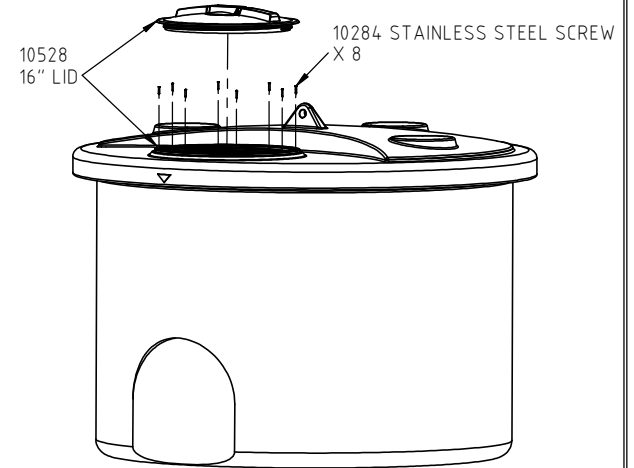
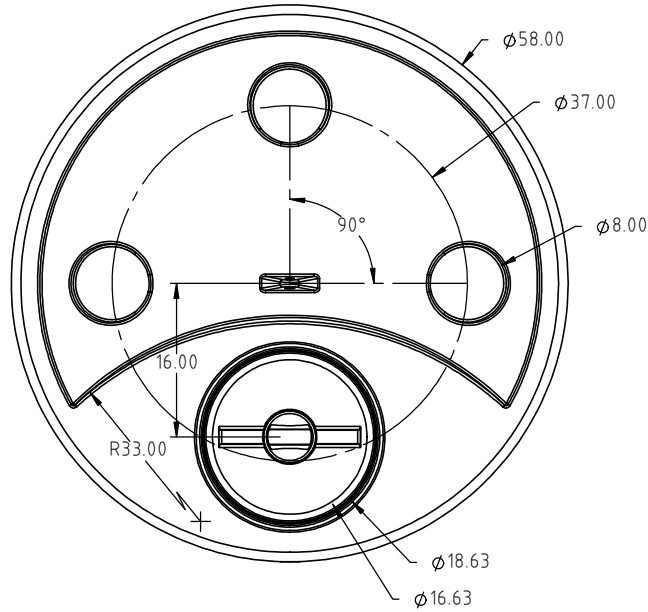

DETAIL A
SCALE 1:10

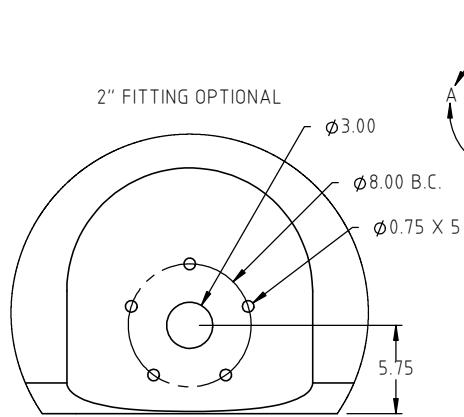

DETAIL B
SCALE 2:25

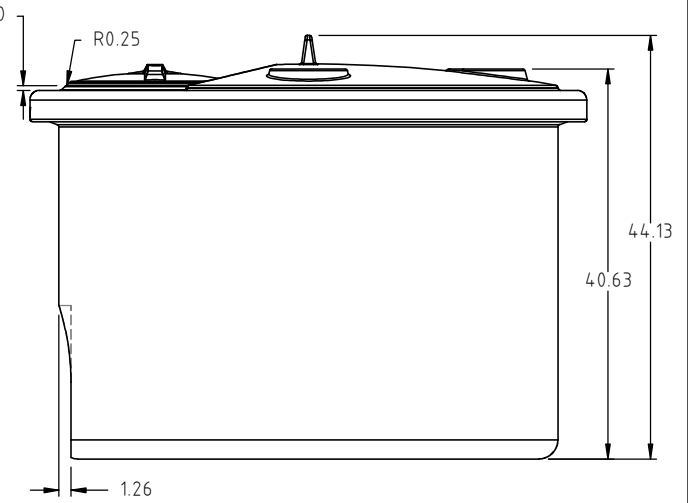
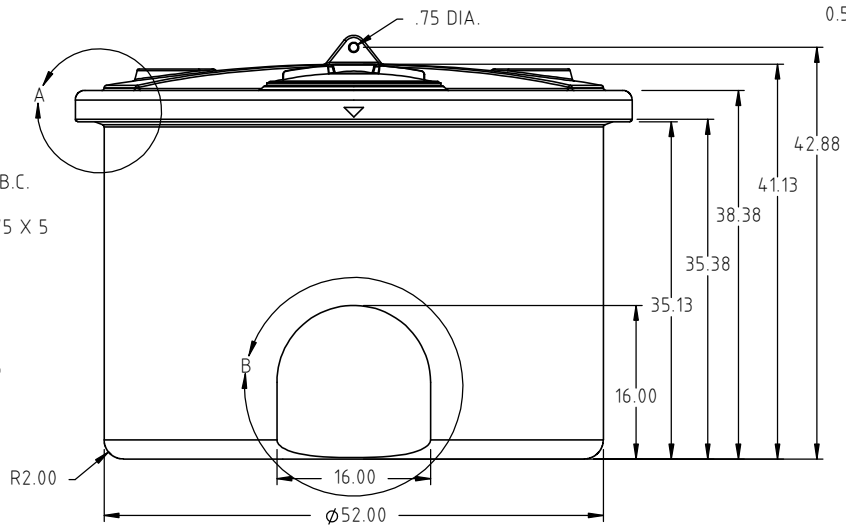

REV	DESCRIPTION	BY / DATE	CCN	DRAWN / DATE ADH 2/19/14	MATERIAL 10420
				APPROD. / DATE REH 8/12/14	
				SHOT WEIGHT: 93 LBS	NOTES: 1.) 0.250 NOM. WALL THICKNESS 2.) PATENT PENDING
				SHIPPING WEIGHT:	
				FINISH:	
ALL DIMENSIONS ARE IN DECIMAL INCHES TOLERANCES UNLESS OTHERWISE SPECIFIED		THIRD ANGLE PROJECTION ANSI 14.5M			
POLYETHYLENE ±1% @ 68°F					
METAL DECIMAL ± .125" FRACTION ± 1/4" ANGLE ± 1°					



4010 HOSPERS DRIVE S. BOX 425, HOSPERS, IOWA 51238-0425

DESCRIPTION 300 GALLON DUAL LINE™ TANK-INNER TANK	
SCALE N.S.	PART NO. DW0300-57-1

Copyright. All information furnished within this document, electronic file or design correspondence is the property of Den Hartog Industries, Inc. and shall not be used, disclosed to others or copied without the expressed written consent of Den Hartog Industries, Inc.

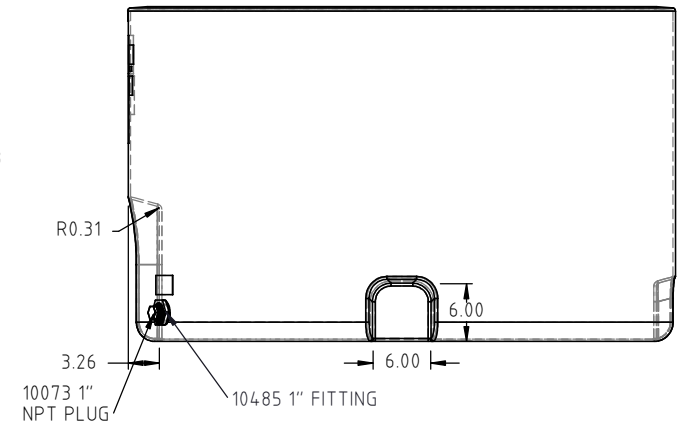
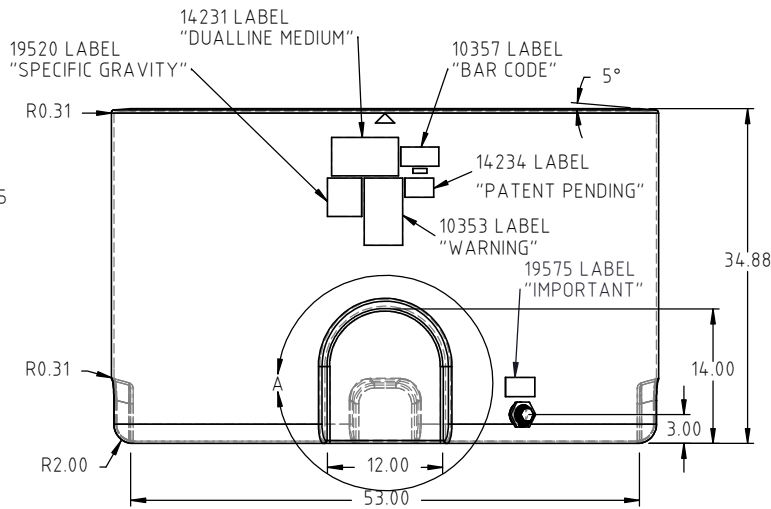
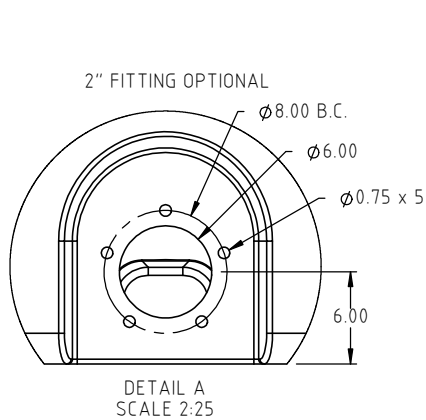
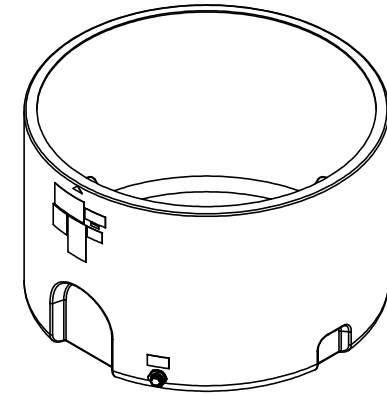
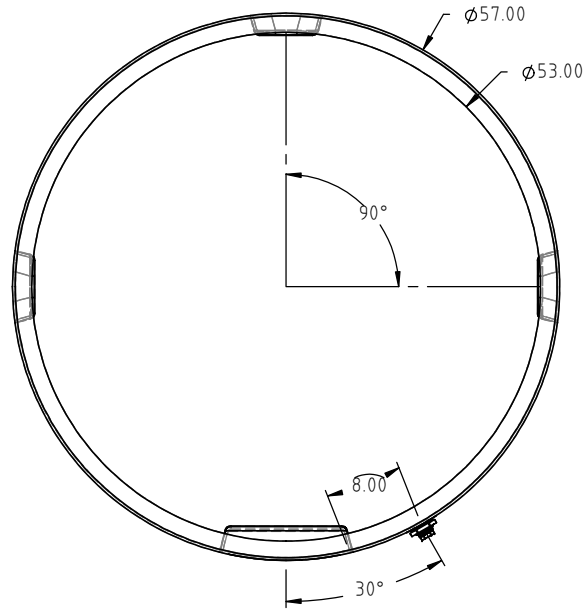

REV	DESCRIPTION	BY / DATE	CCN	DRAWN / DATE ADH 10/16/12	MATERIAL 10420
				APPRO. / DATE REH 8/12/14	
ALL DIMENSIONS ARE IN DECIMAL INCHES TOLERANCES UNLESS OTHERWISE SPECIFIED		THIRD ANGLE PROJECTION ANSI 14.5M		SHOT WEIGHT: 90 LBS.	NOTES: 1.) 0.240 NOM. WALL THICKNESS 2.) PATENT PENDING
POLYETHYLENE ±1% @ 68°F		METAL DECIMAL ± .125" FRACTION ± 1/4" ANGLE ± 1°		SHIPPING WEIGHT: 73 LBS.	
				FINISH:	



4010 HOSPERS DRIVE S. BOX 425, HOSPERS, IOWA 51238-0425

DESCRIPTION 300 GALLON DUAL LINE™ TANK- OUTER TANK	
SCALE N.S.	PART NO. DW0300-57-2

Copyright. All information furnished within this document, electronic file or design correspondence is the property of Den Hartog industries, Inc. and shall not be used, disclosed to others or copied without the expressed written consent of Den Hartog Industries, Inc.

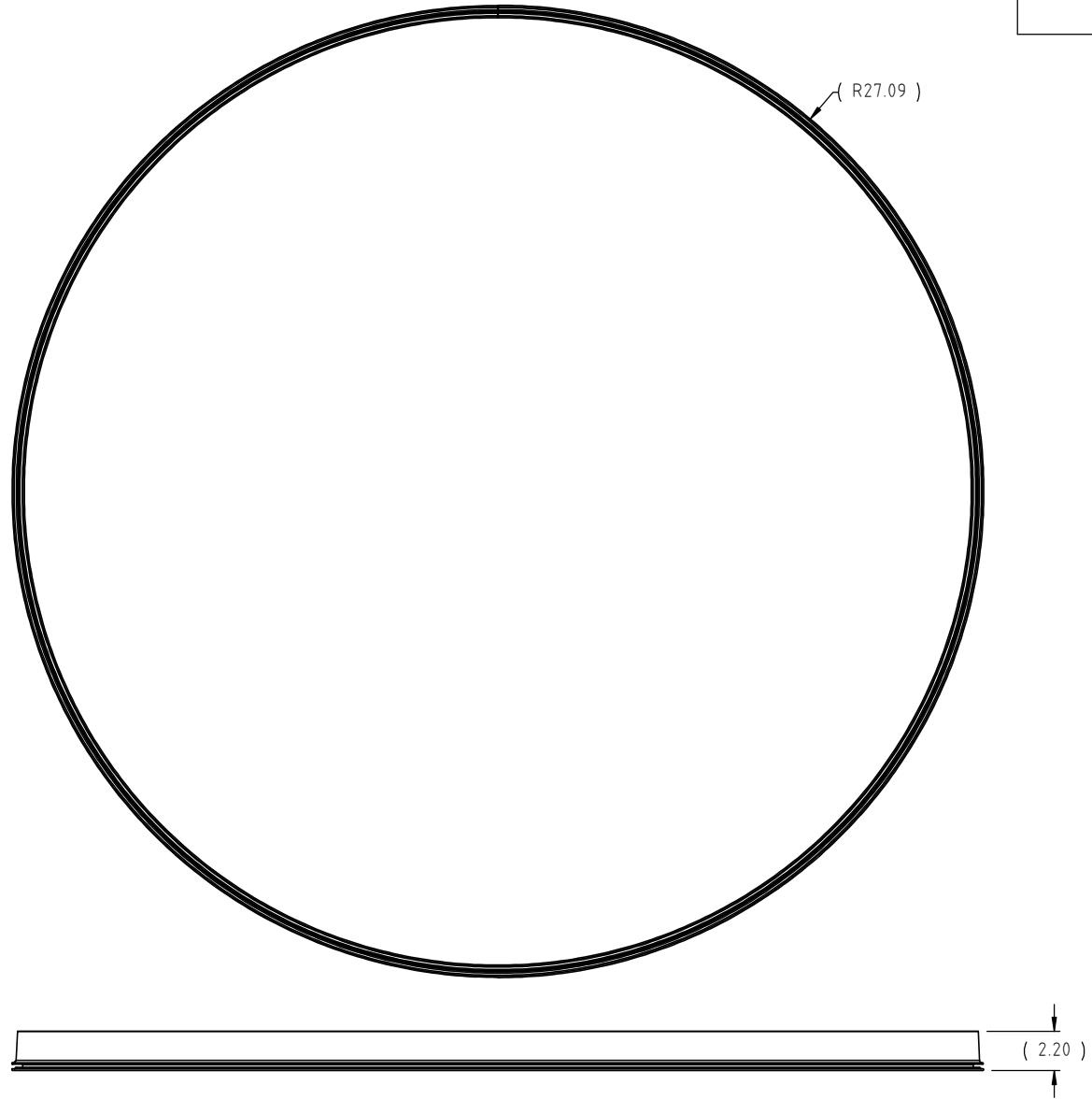

				DRAWN / DATE ADH 7/14/14	MATERIAL EPDM		
				APPROD. / DATE REH 10/30/14			
REV	DESCRIPTION	BY / DATE	CCN				
ALL DIMENSIONS ARE IN DECIMAL INCHES TOLERANCES UNLESS OTHERWISE SPECIFIED		THIRD ANGLE PROJECTION ANSI 14.5M		SHOT WEIGHT:	NOTES:	4010 HOSPERS DRIVE S. BOX 425, HOSPERS, IOWA 51238-0425	
POLYETHYLENE		METAL DECIMAL ± .125" FRACTION ± 1/4" ANGLE ± 1°		SHIPPING WEIGHT:	1.) PURCHASED	DESCRIPTION 57 INCH DIAMETER DOUBLE WALL TANK- GASKET	
±1% @ 68°F				FINISH:	2.) 166.50 IN LENGTH	SCALE N.S.	PART NO. 14213

DW0300-57 DOUBLE WALL TANK STANDARD COMPONENTS

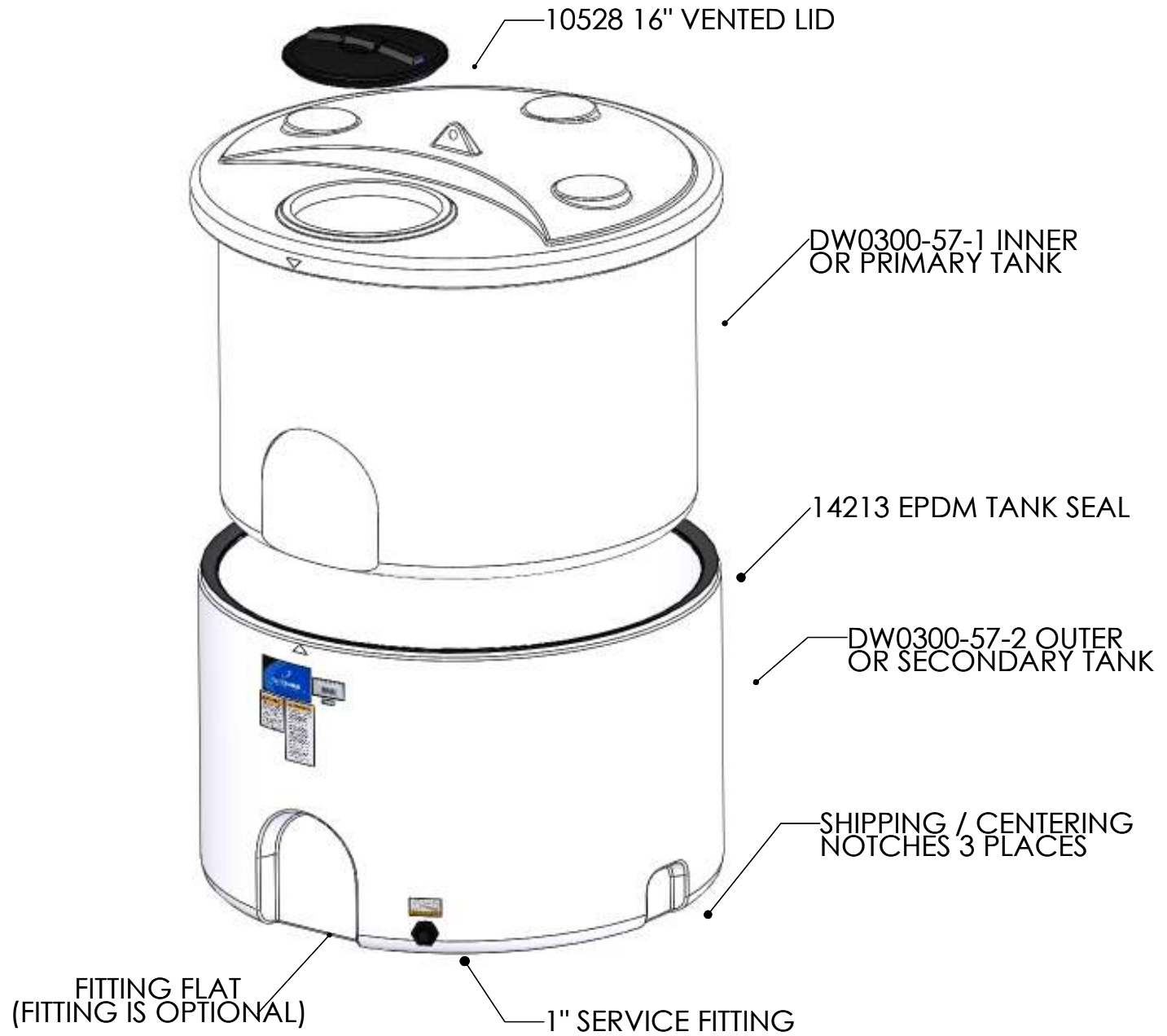

© DEN HARTOG INDUSTRIES, INC.

Copyright. All information furnished within this document, electronic file or design correspondence is the property of Den Hartog Industries, Inc. and shall not be used, disclosed to others or copied without the expressed written consent of Den Hartog Industries, Inc.

KEY	PART NUMBER	DESCRIPTION	QTY.
1	19564	2" FITTING RING WELDMENT	1
2	19555	2" FITTING GASKET	2
3	19566	2" FITTING RING	1
4	19568	NUT, 1/2" SS	5

19563

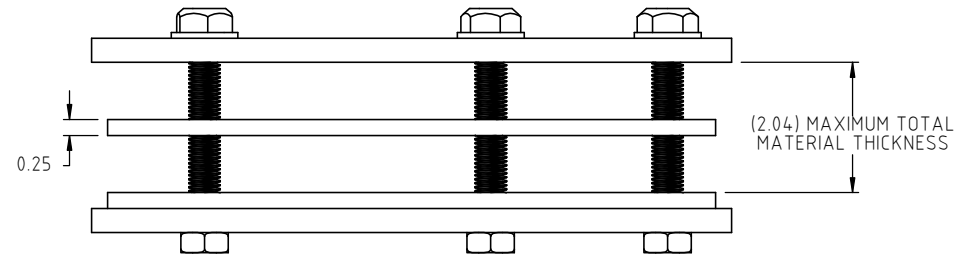
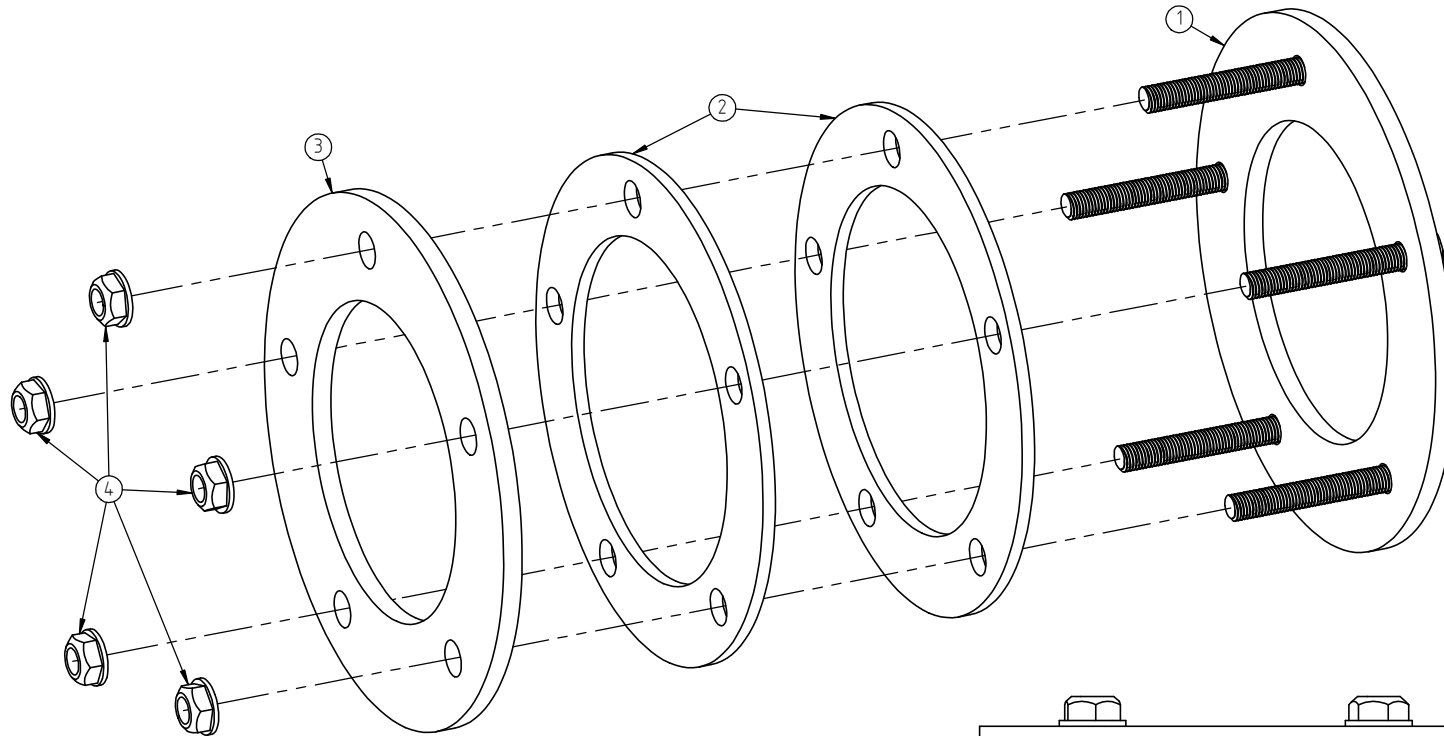

				DRAWN / DATE ADH 9/26/14	MATERIAL SEE COMPONENTS
				APPRO. / DATE REH 10/29/14	
REV	DESCRIPTION	BY / DATE	CCN	SHOT WEIGHT:	NOTES: 1.) PATENT PENDING
				SHIPPING WEIGHT:	
				FINISH: NONE	



4010 HOSPERS DRIVE S. BOX 425, HOSPERS, IOWA 51238-0425

DESCRIPTION 2" DUAL LINE™ TANK FITTING RING ASSEMBLY	
SCALE N.S.	PART NO. 19563

ALL DIMENSIONS ARE IN DECIMAL INCHES
TOLERANCES UNLESS OTHERWISE SPECIFIED
POLYETHYLENE
±1% @ 68°F

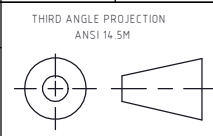

METAL
DECIMAL ± .125"
FRACTION ± 1/4"
ANGLE ± 1°

© DEN HARTOG INDUSTRIES, INC.

Copyright. All information furnished within this document, electronic file or design correspondence is the property of Den Hartog Industries, Inc. and shall not be used, disclosed to others or copied without the expressed written consent of Den Hartog Industries, Inc.

19563 INSTALL

KEY	PART NUMBER	DESCRIPTION	QTY.
1	10508	BULKHEAD, 2" FITTING	1
2	19563	2" DOUBLE WALL RING ASSEMBLY	1
3	10488		1

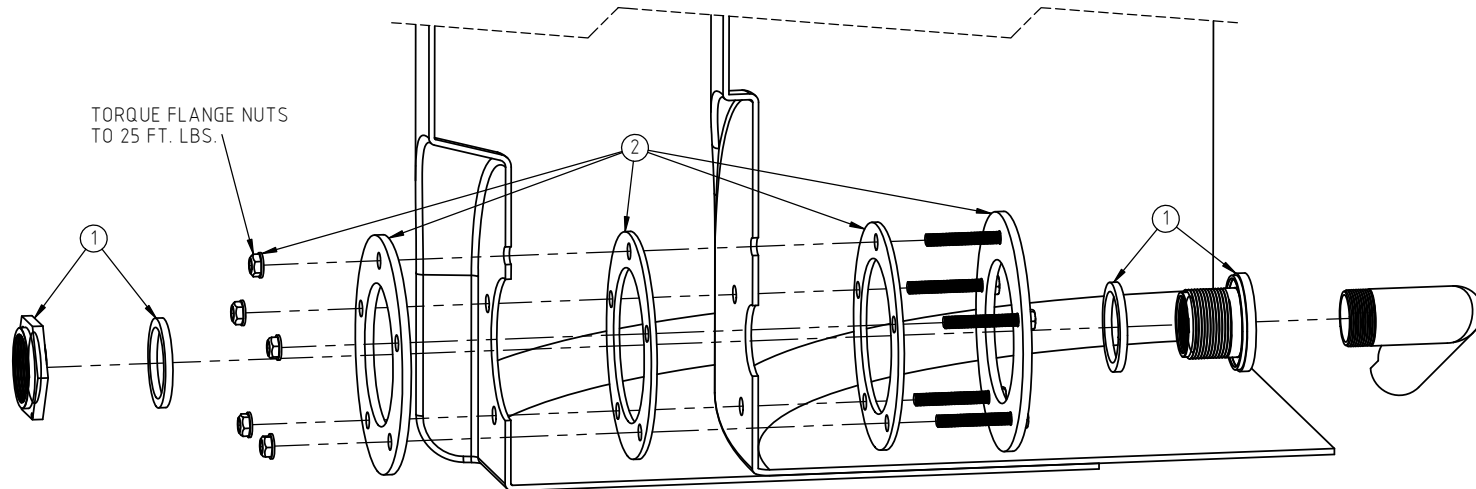
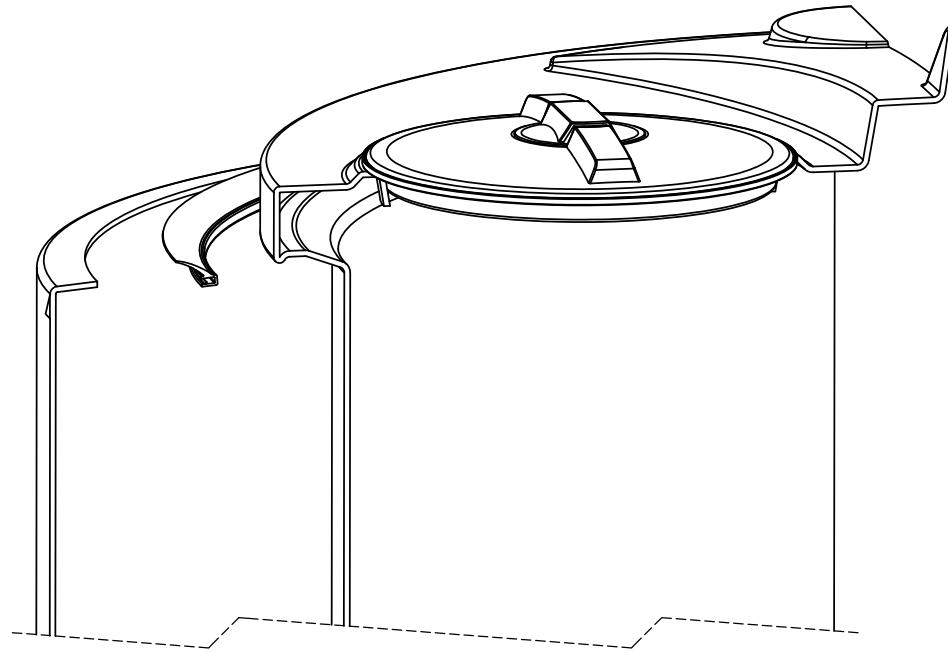

				DRAWN / DATE ADH 10/16/13	MATERIAL
				APPRD. / DATE REH 10/29/14	
REV	DESCRIPTION	BY / DATE	CCN	SHOT WEIGHT:	NOTES:
				SHIPPING WEIGHT:	1) PATENT PENDING
				FINISH:	
ALL DIMENSIONS ARE IN DECIMAL INCHES TOLERANCES UNLESS OTHERWISE SPECIFIED		THIRD ANGLE PROJECTION ANSI 14.5M			
POLYETHYLENE ±1% @ 68°F					
METAL DECIMAL ± .125" FRACTION ± 1/4" ANGLE ± 1°					



4010 HOSPERS DRIVE S. BOX 425, HOSPERS, IOWA 51238-0425

DESCRIPTION	OPTIONAL 2" FITTING ASSEMBLY INSTALLATION	
SCALE	N.S.	PART NO. 19563 INSTALL